

All about

MAGNETOS

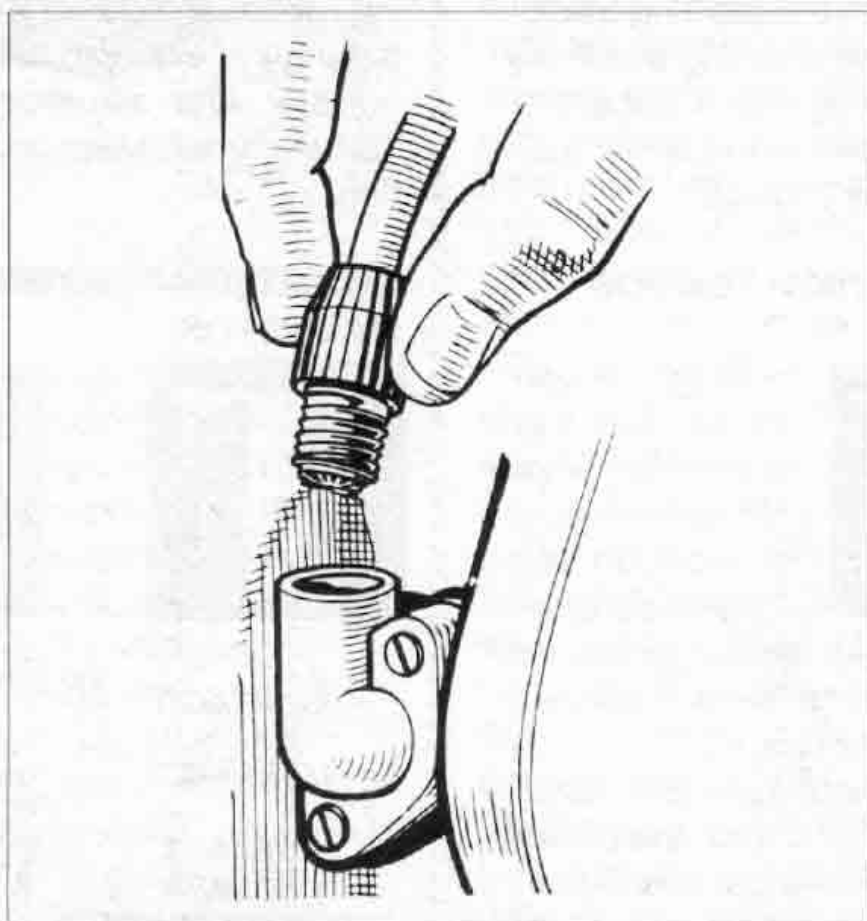

THE CLASSIC
MotorCycle

HIGH TENSION PICK-UP

A

bout every 6000 miles, remove the high tension pick-up, secured by means of a clip or two screws. Wipe the moulding with a clean dry cloth. Check that the carbon brush moves freely in its holder, but take care not to stretch the brush spring unduly. If the brush is dirty, clean it with a cloth moistened with petrol. If the brush is worn to within $\frac{1}{8}$ in of the shoulder it must be renewed.

Before re-fitting the high tension pick-up, clean the slip-ring track and flanges by pressing a soft dry cloth on the ring with a suitably shaped piece of wood, while the engine is slowly turned.

RENEWING HIGH TENSION CABLES

W

hen high tension cables show signs of cracking or perishing, they must be replaced, using 7mm neoprene-

covered rubber ignition cable.

To replace a high tension cable proceed as follows:

Remove the metal washer and moulded terminal from the defective cable. Thread the new cable through the moulded terminal and cut back the insulation for about $\frac{1}{8}$ in. Pass the exposed strands through the metal washer and bend them back radially. Screw the terminal into the pick-up moulding.

MANUAL IGNITION TIMING CONTROL

W

ith manual advance and retard, retard the hand ignition control for starting but advance it as soon

as the engine is running at speed.

For normal running, the control should be kept in the advance position, and should be retarded only when the engine is labouring on full throttle.

Any slackness in the cable can be taken up by sliding the waterproofing rubber shroud up the cable and turning the exposed hexagon adjuster. After adjusting, return the rubber shroud to its original position.

ROTATING ARMATURE MAGNETOS

T

hese magnetos have the magnet cast in the body and the armature and contact breaker rotate within the

(a) Face Cam Type

CONTACTS

LOCK NUT

CONTACT
BREAKER

SECURING SCREW

SCREW CARRYING
LUBRICATION

SCREW SECURING
CONTACT

BREAKER SPRING

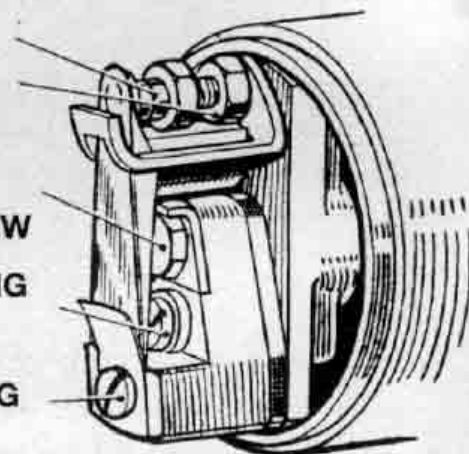

casting. Two designs of contact breaker are in common use. Single cylinder magnetos usually employ the face cam type (a), while magnetos for twin cylinder engines have the ring cam type shown in (b).

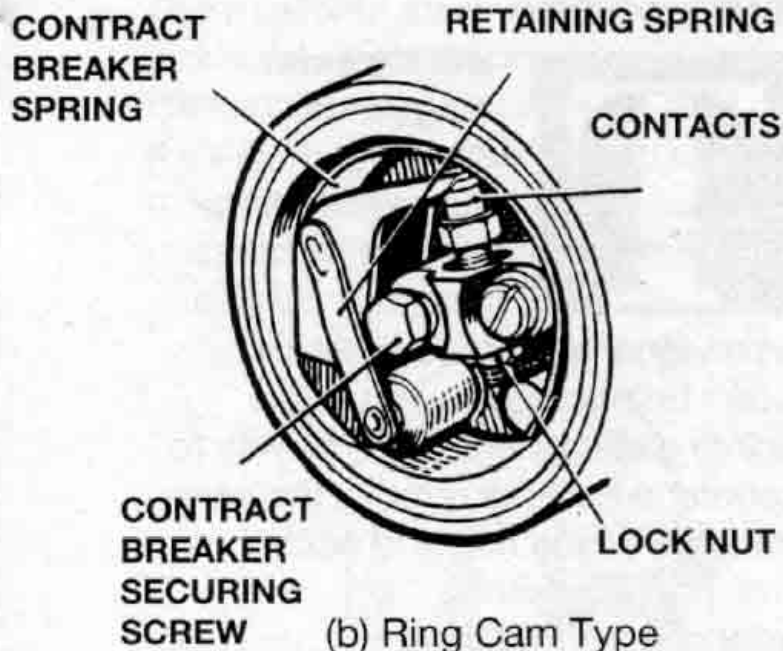

LUBRICATION - EVERY 3000 MILES

F

ace Cam Type.

The cam is lubricated from a wick contained in the contact breaker base. To reach the wick, take out the screw which secures the spring arm carrying the moving contact and lift off the backing spring and spring arm. The screw carrying the wick can then be withdrawn. At the same time, unscrew the contact breaker securing screw, take the tappet which operates the contact spring from its housing and lightly smear with thin machine oil. Extract the spring circlip and remove the face cam.

Lightly smear both sides of the cam with light grease. When refitting, take care that the stop peg in the housing and the plunger of the timing control engage with their respective slots. A recess is provided for the eye of the circlip. When re-fitting the spring arm see that the backing spring is fitted on top with its bent portion facing outwards (see Fig, page 2).

Ring Cam Type. The cam is supplied with lubricant from a felt pad contained in a pocket in the contact breaker housing. A small hole in the cam, fitted with a wick, enables the oil to find its way to the surface of the cam. Remove the contact breaker cover, turn the engine over until the hole in the cam can be clearly seen and then carefully add a few drops of thin machine oil. Do not allow any oil to get on or near the contacts. If the cam ring is removed, the wick should be taken out and soaked in thin machine oil. Wipe the wick to remove surplus oil, before replacing.

The contact breaker rocker arm pivot also requires lubrication and the complete contact breaker must be removed for this purpose. Take out the hexagon-headed screw from the centre of the contact breaker and carefully lever the contact breaker off the tapered shaft on which it fits. Push aside the rocker arm retaining spring, lift off the rocker arm and lightly smear the pivot with light grease. Remove the cam ring, which is a sliding fit in its housing, and lightly

smear inside and outside surfaces with light grease.

Removal and refitting of the cam can be made easier if the handlebar control lever is half retarded, thus taking the cam away from its stop pin. Apply one or two drops of thin machine oil to the felt cam lubricator in the housing. Refit the cam, taking care that the stop peg in the housing and the timing control plunger engage with their respective housing and the timing control plunger engage with their respective slots.

If an earthing brush is fitted at the back of the contact breaker base, see that it is clean and can move freely in its holder, before refitting the contact breaker.

When re-fitting the contact breaker, see that the projecting key on the tapered portion of the contact breaker base engages with the keyway cut in the magneto spindle, otherwise the timing of the magneto will be effected. Replace the contact breaker securing screw and tighten with care.

CLEANING CONTACTS

Every 6000 miles, take off the contact breaker cover and examine the contact breaker. Dirty or pitted contacts can be cleaned with a fine carborundum stone, or, if this is not available, very fine emery cloth may be used. Wipe away any dirt or metal dust with a cloth moistened with petrol. Contact breaker springs

should be examined and any rust removed. The contacts can be removed for cleaning as described under Lubrication. After cleaning, check the contact breaker setting

HINTS & TIPS

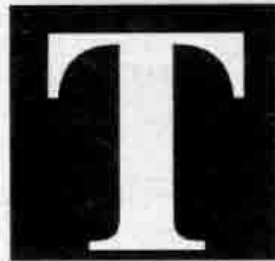

win Cylinder Magnetos

Check that the two cams on the contact breakers have not worn to

an unequal height, otherwise it won't be possible to adjust the points gaps accurately. One way to counter wear is to remove the cams from the timing ring and pack them with paper washers.

Intermittent Misfiring

Intermittent misfiring on magneto contact breaker points may be caused by dampness of the bush of the rocking arm, or even swelling of the fibre pad at its end. This will prevent the points from closing completely, and can be checked by sliding a piece of white paper behind the points and examining them squarely with a strong light.

Slipped Magneto Timing

On many engines with chain driven magnetos, the sprockets are not keyed onto the magneto shaft but held by means of a taper and locknut. Unless this locknut is kept dead tight, the timing may slip due to the power put through the chain drive. Excessive stretching of the magneto chain will have a similar effect. An easy check is to retard the ignition control a touch while

fully underway. If the engine slows dramatically the ignition needs advancing, because, correctly adjusted, slightly retarding the ignition should not affect the running of the engine.

Magneto Chain Adjustment

The minimum slack in a magneto chain, as recommended by Renolds, should not exceed $\frac{1}{8}$ in (6mm). One way of adjusting a slack magneto chain is to insert packers under one side of the magneto

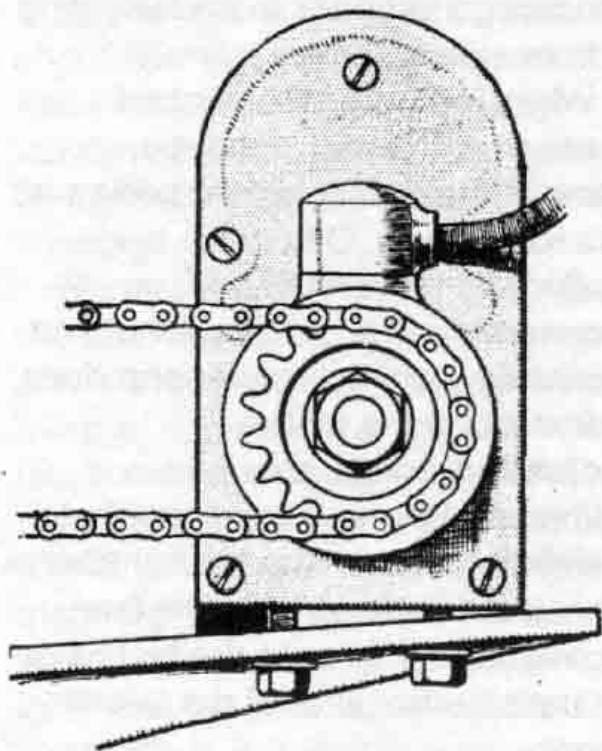

body. Indeed, this was recommended practice on post-war AJS machines. An alternative would be to elongate the magneto fixing holes into the more usual slots. In this original tip of 1921, it was suggested as a way of extending chain life beyond the natural length of the slots in the magneto platform. In this case a replacement chain would be preferable.

Magneto Pick-up

On many models it is awkward to undo the screws of the magneto pick-up because of lack of space for a screwdriver. If they are replaced by socket head screws, there is usually enough room for an Allen key.

Magneto Spring Clip

Loose spring clips on magneto covers can be packed out with a short piece of rubber tubing. Broken clips can be replaced by a short length of hacksaw blade, cleaned up and drilled at either end. One end is rivetted to the existing stub, the other fitted with a tiny nut and screw to locate into the indentation in the cover.

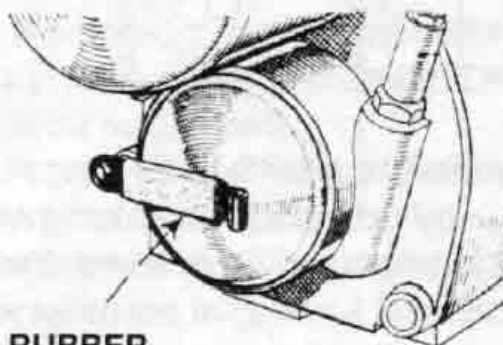

RUBBER TUBING

Stop your contact breaker cover rattling about with these useful dodges.

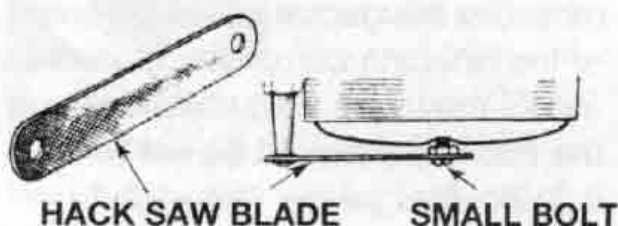

HACK SAW BLADE

SMALL BOLT

Armature Bearing Removal

To remove tight armature bearings, grip them in the vice by bending into a U a piece of 2mm rod. Drive the shaft out of the bearing using a soft copper drift, making sure that the body of the armature is supported at all times.

WELDING
ROD

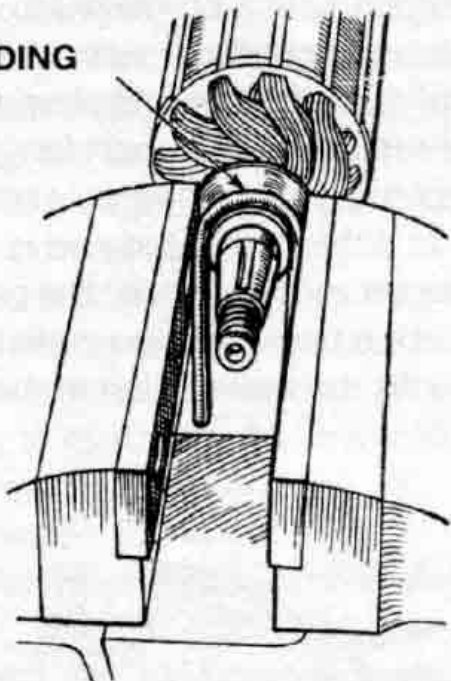

Contact Breaker Gap Settings

Correctly set contact breaker gaps are important for the efficient and economical running of any engine. The correct gap settings for Lucas magnetos and distributors are as follows: rotating armature magnetos, 0.012-0.015in; rotating magnet magnetos, 0.010-0.012in; coil ignition contact breakers, 0.014-0.016in.

When setting the contact breaker gap of a twin cylinder magneto, measure the gap at both positions of the opening cam. The measurements may vary, and the smaller of the two gaps should be set to 0.012in; the greater gap should then be between 0.012 and 0.015in.

By setting the gaps in this manner the magnetic timing of the magneto is preserved.

Cleaning Contact Breaker Points

If emery cloth is used to clean contact breaker points, always wipe the points over carefully afterwards with some petrol on a clean rag.

Contact Breaker Removal

When dismantling the contact breaker the unit is often still tight on the taper after the stud has been removed. The taper seal can be broken without damage by pushing the fixing stud back in and wiggling it from side to side.

When removing the contact breaker of the ring cam type, remove the spring before prising off the rocker arm. Otherwise the spring will be twisted and, on reassembly, the points will not line up. Make sure the rocker arm does not stick on the pinion.

Adjusting points gap

When making any adjustments to points gap or ignition timing, always check the settings after the final tightening up, in case the last twist of the spanner altered the adjustment.

ARMATURE & CONDENSER TEST



Armature windings and the condenser of the magneto or Magdyno can be tested by temporarily replacing the contact breaker screw in the threaded end of the shaft and running a cable

temporarily replacing the contact breaker screw in the threaded end of the shaft and running a cable

from it to the positive terminal of a test battery, with an ammeter in series. Another cable should be run from the negative side of the battery to the armature earthing track. A reading of some 4 amp should be shown if the primary winding is sound. To test the secondary circuit leave the battery positive connection as it is; twist a piece of bare wire around the slip ring and lead it to within $\frac{1}{4}$ in of the armature body. The lead from the negative side of the battery, flicked against the opposite end of the armature shaft, should produce a healthy spark. If none is forthcoming, then condenser trouble is possible: alternatively there may be a fault in the HT windings.

Withdrawing the armature impairs the quality of the permanent magnet and it is desirable to place a keeper, a bar of soft iron or a spanner will do, across the pole pieces. Nifal, an alloy containing nickel, iron and aluminium, has been used for magneto magnets since the mid Thirties and is less susceptible to this trouble than was the previously-used cobalt steel which, if a keeper was not put in position at once, deteriorated considerably.

Before reassembling the magneto, check that the pick-up segment in the slip-ring is flush; a sharp edge will result in a rapidly worn carbon brush and a harmful coating of dust on the pick-up and earthing contact points. The armature, reassembled in the magneto body and, if necessary, properly shimmed, should spin freely on its two bearings.

CONDENSER FAULT FINDING



The condenser, sometimes called a capacitor, absorbs current which might otherwise

across the contact breaker points at the moment of separation. Such an occurrence would not only impair induction, but quickly burn away the hard contact points. Slight, spasmodic sparking can sometimes be detected, particularly if, as a test, the contact breaker cover is removed with the engine running at night. It does not usually indicate a condenser fault, however. If, on the other hand, the flash-over is constant, taking the form of a flame rather than a spark, and starting and slow-running are noticeably poor, then condenser trouble may well be suspected.

An open-circuited condenser is betrayed by a white deposit of tungsten around the contact breaker points, as well as by arcing. A short-circuited condenser cuts out the contact breaker and stops the engine altogether.

EARTHING BRUSH

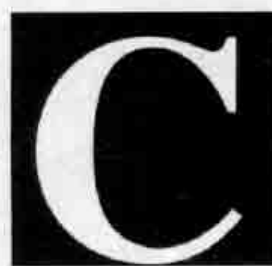

Check the condition of the earthing brush. If it is not doing its job, ie that of a last-link contact in the

earthed return route of the HT ignition circuit, either the spark at the plug points will be bad, or earthed current will tend to find a

return path through the bearings. That means pitted races, a trouble which can occur in the event of the paper bearing cups having been faultily assembled, or having deteriorated over a period.

LUCAS & BTH MAGNETOS

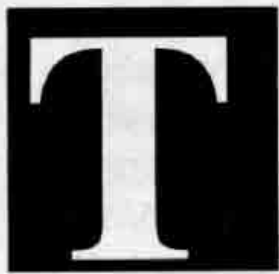

The K2F Lucas magneto is fitted to a large number of vertical twin cylinder engines. In working on this

instrument important items to note are the insulating paper cup and bearing assembly, and the use of shims to give armature end clearance.

The main parts of a BTH magneto are, as shown on the opposite page: (1) the contact breaker cover; (2) the contact breaker assembly; (3) the cam ring; note the slot for the eccentric timing peg; (4) the contact breaker housing; note the eccentric peg on the left-hand side; (5) shims to adjust armature end float; (6) the fibre washer which insulates the ball-race; (7) the armature; (8) the magneto body, pick-up brush and holder.

LUCAS AUTOMATIC ADVANCE & RETARD



The magnetos fitted to some motor cycles are provided with an automatic timing control. This mechanism automatically varies the firing

point according to the speed of the engine thus relieving the rider of the necessity for adjusting the timing. Its advantages are particularly evident when accelerating and during hill climbing, the danger of pre-ignition, knocking or pinking being very much reduced.

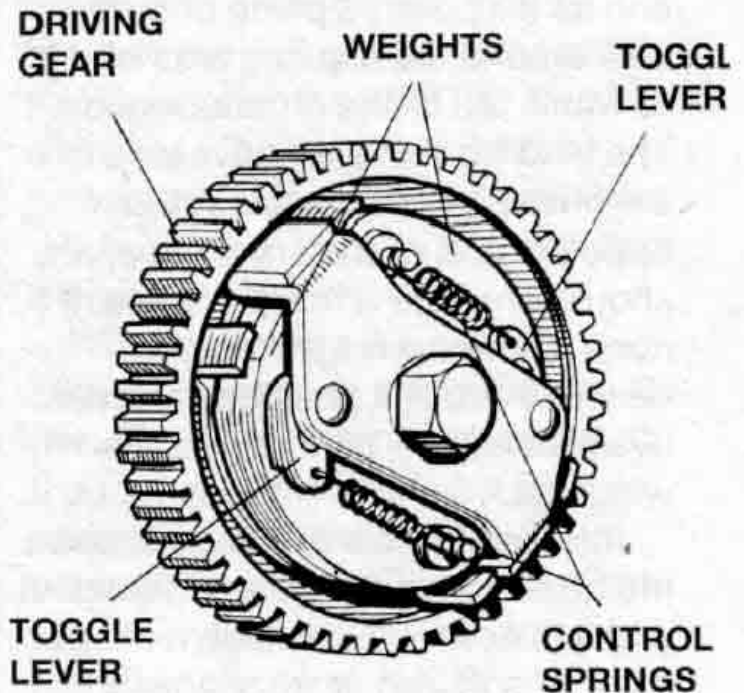

The control consists of a driving gear carrying a plate fitted with two pins. A weight is pivoted on each pin and the movement of the weight is controlled by a spring connected between the pivot end of the weight and a toggle lever pivoted at approximately the centre of the weight. Holes are provided in each toggle lever, in which locate pegs on the underside of a driving plate secured to the magneto spindle. This plate is also provided with stops which limit the range of the control.

When the magneto is stationary the weights are in the closed posi-

SEGMENTS
FOLD ROUND
RACE WHEN
FITTED

LUCAS K2F MAGNETO

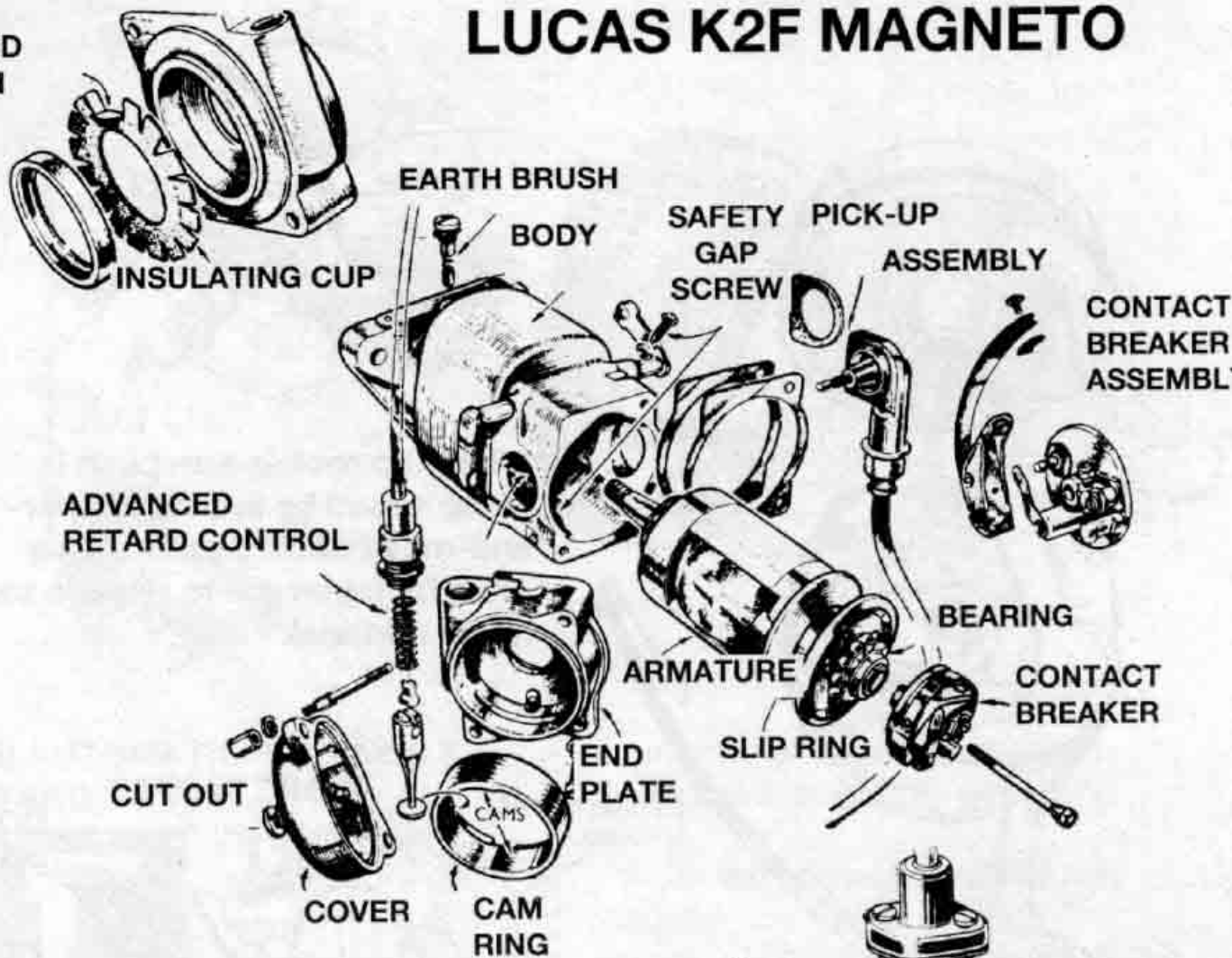

1. Contact breaker cover
2. Contact breaker assembly
3. Camring with slot for eccentric timing peg
4. Contact breaker housing
5. Shims to adjust end float
6. Fibre insulating washer
- 7 Armature
8. Magneto body, pick-up brush and holder.

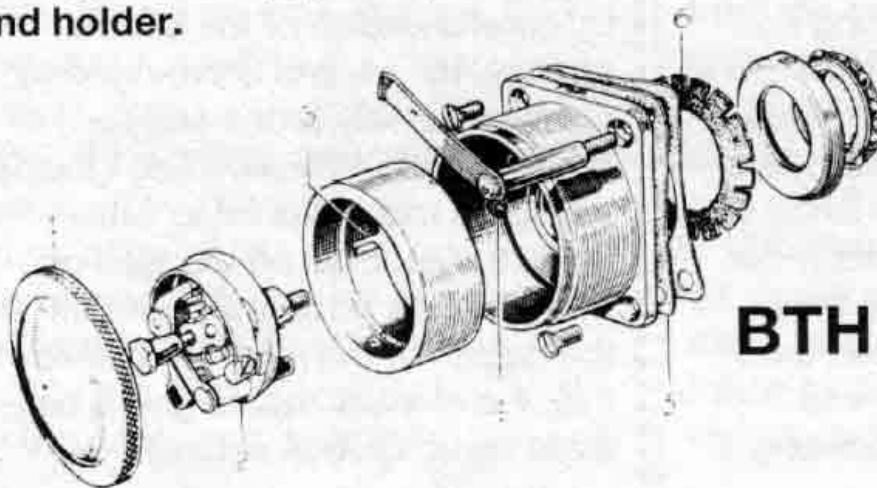
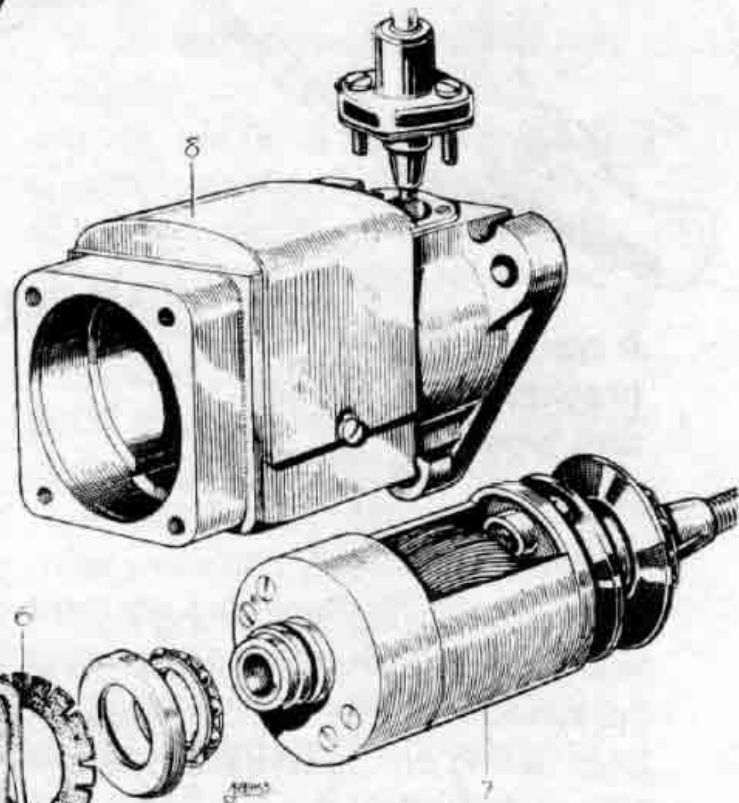

BTH MAGNETO

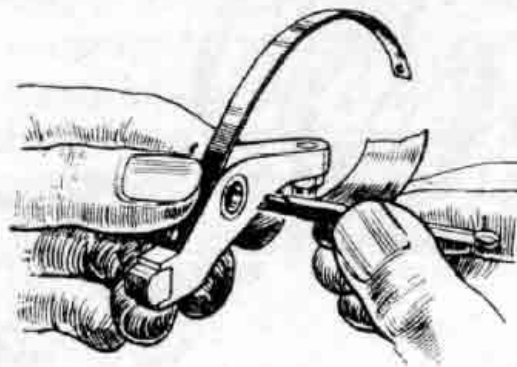
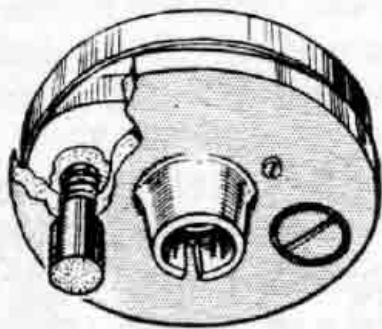

When the rocker-arm bush is being eased by the sandpaper-and-matchstick method, care must be taken not to remove too much material.

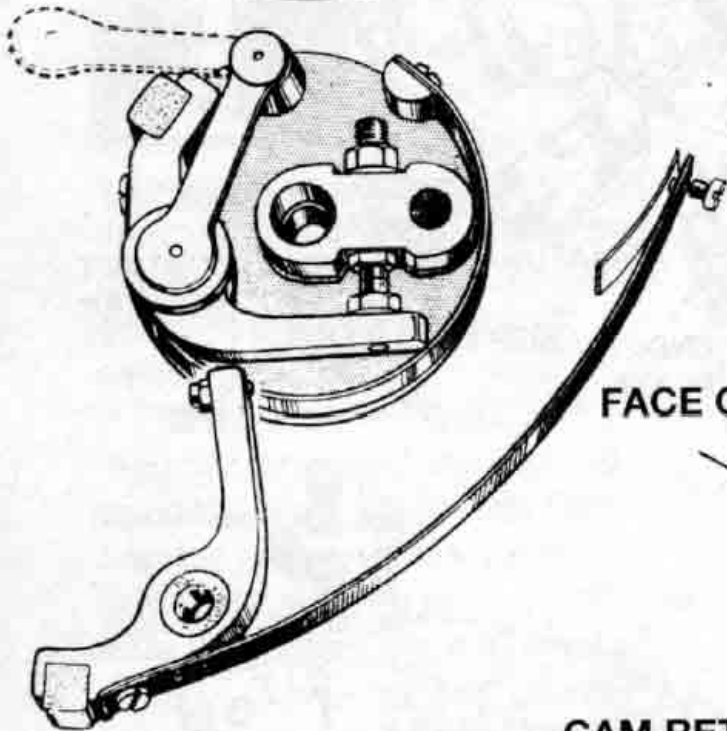

A typical contact breaker of the rocker arm type.

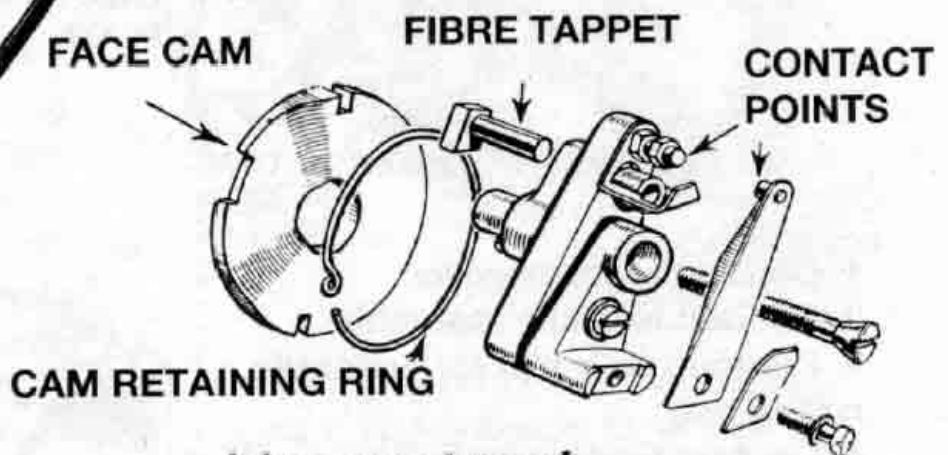

A face-cam type of contact breaker partially dismantled.

tion, and the magneto timing is retarded for starting purposes. As the speed is increased, centrifugal force acting on the weights overcomes the restraining influence of the springs and the weights move outwards, causing relative movement to take place between the driving gear and the magneto spindle, so advancing the timing.

- By careful design of the control
- springs, the control is arranged to
- conform closely to the engine
- requirements. When setting ignition
- timing on machines fitted with
- units, they should be wedged gen-
- tly in the fully advanced position. If
- the design of the machine disallows
- this, the manual should give a sep-
- arate static ignition setting.

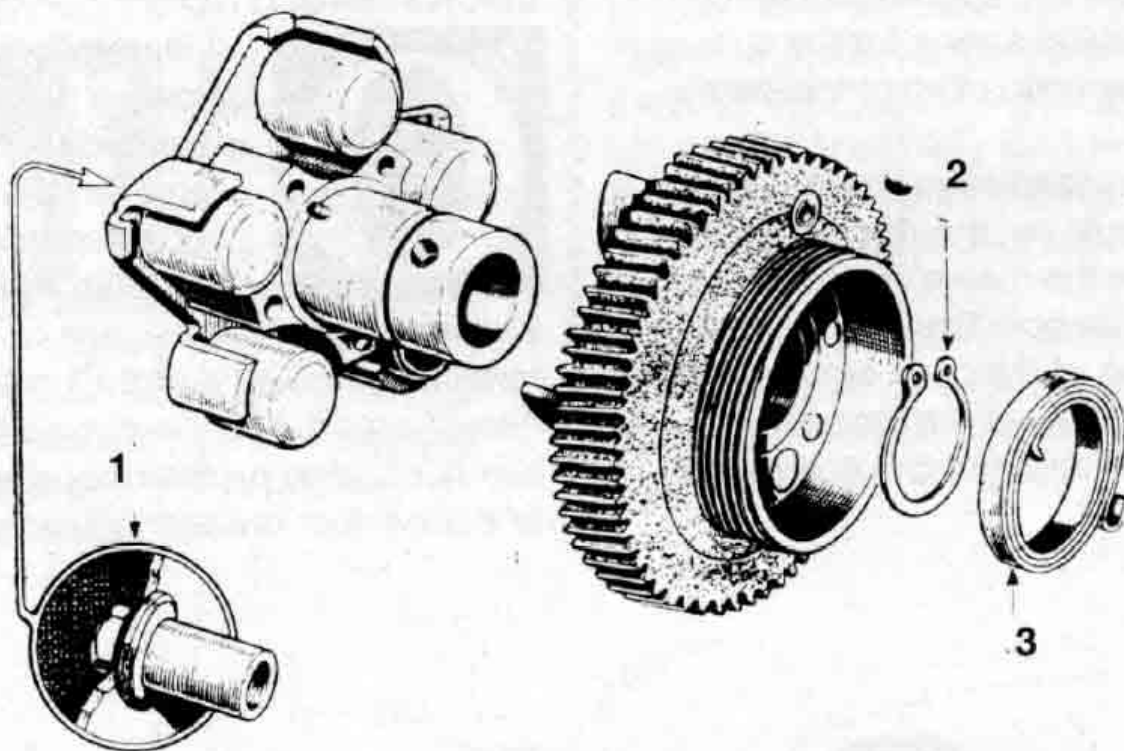

BTH AUTOMATIC ADVANCE & RETARD

T

he automatic retarding mechanism: (1) the self-withdrawing nut with shoulder against moving cage plate; (2) the circlip to locate the oscillating hub relative to the gear wheel and (3) the spring to ensure that the moving cage returns to the full retard position.

The BTH unit was popular with Triumph, Velocette and Vincent. This is how it works. A cage, free to oscillate relative to the timing gear wheel, is attached to the armature shaft. Five rollers are interposed between five curved ears on the outer edge of this cage, and five corresponding ears on a cage riveted to the gear wheel. A spring inside the oil slinger pulls the oscillating cage, and, therefore, the

armature shaft, backwards when the engine is stationary or running slowly.

When the engine speed reaches 1000rpm, the rollers, or bob wrights, are flung outwards, causing a wedging action between the ears of the two cages, and moving the armature shaft forward relative to the driving gear, until the fully advanced position is reached at 2000 engine rpm. Replacements are supplied as complete units.

However, the outer cage and roller assembly can be separated from the timing wheel, if by any chance the latter becomes damaged, by removing the coil spring and circlip inside the oil from the hub of the oscillating cage.

The timing wheel is riveted to the oil slinger and one half of the roller cage, and no attempt should be made to dismantle this sub-unit. A pair of circlip expanders are highly

desirable for removing the circlip, which is too strong for the successful application of electrical screwdrivers.

On reassembling, the oscillating cage must have a little end float, likewise the rollers must also have end clearance. Great care should be taken of the cage ears, which, if bent, will upset the amount of advance and retard automatically provided.

LUCAS MAGDYNO

O

ur illustration shows a machine arranged for driving in an anti-clockwise direction. With a clockwise machine the positions of the terminals marked + and F1 are interchanged, and the control brush box is situated on the opposite side of the contact breaker housing.

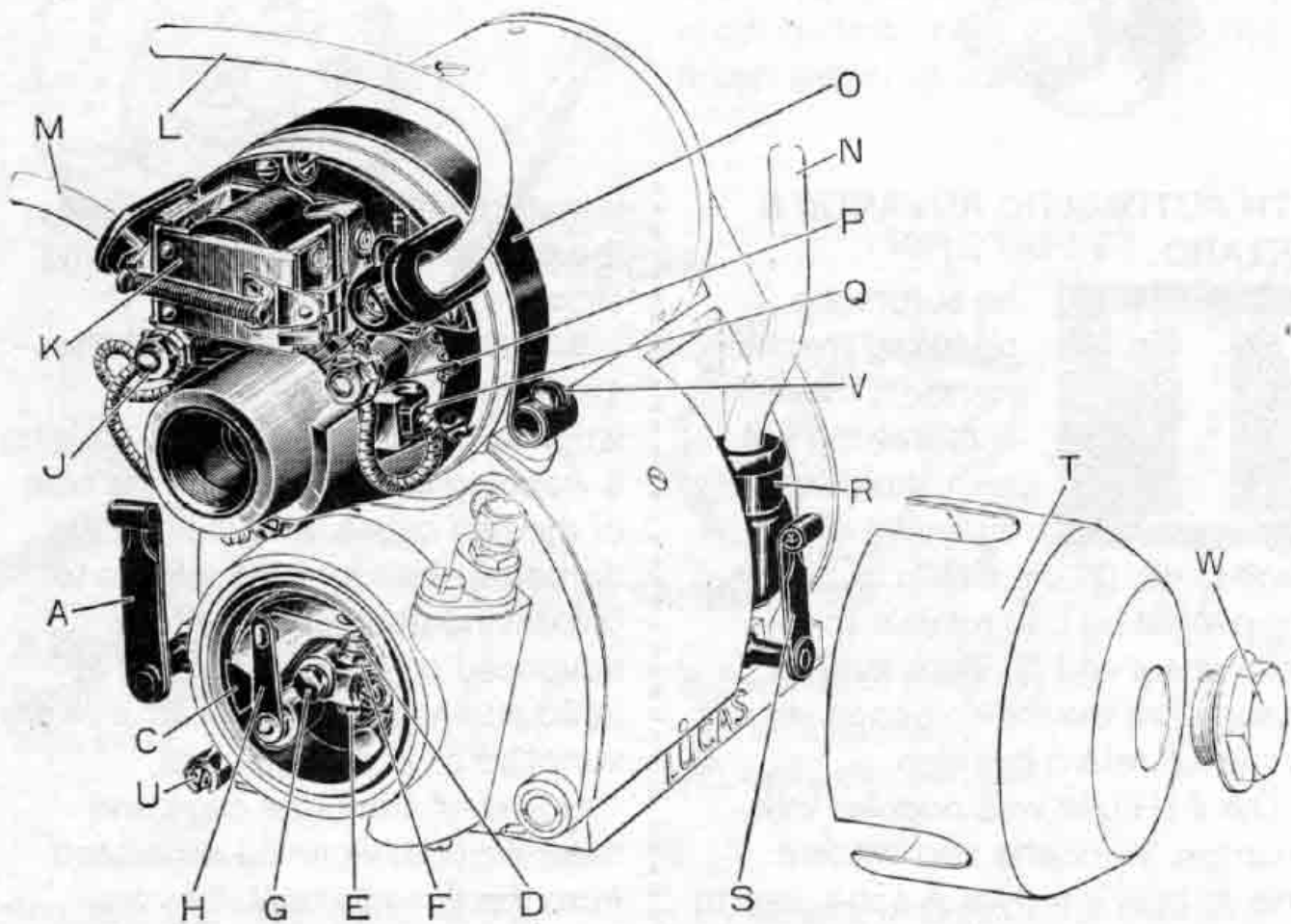

A Securing spring for contact breaker cover. **B** Contact breaker cover. **C** Fibre heel. **D** Contact points. **E** Locking nut. **F** Adjustable contact. **G** Contact breaker fixing screw. **H** Locating spring. **J** Nut securing brush eyelet. **K** Cut-out. **L** Cable to headlamp switch terminal F1.

M. Cable to headlamp switch terminal +. **N** High tension cable to spark plug. **O** Dynamo strap. **P** Brush spring lever. **Q** Carbon brush. **R** Pick-up. **S** Spring for pick-up. **T** End cover. **U** Earthing terminal. **V** Dynamo strap screw. **W** End cover fixing screw.

MAGDYNO TIPS

M

any suggest it is easier to set Magdyno ignition timing by removing the idler gear instead of the

Magdyno gear. The Royal Enfield factory admitted it was quicker but: "In general it will be found necessary to move the Magdyno gear

slightly before the idler gear teeth drop into mesh; as there are 40 teeth on the Magdyno gear the movement necessary (plus or minus half a pitch) could be $4\frac{1}{2}$ degrees, which is equal to 9 degrees of crankshaft rotation."

When fitting a new fibre pinion, clean the teeth of adjacent pinions of any fibre dust, or that too will soon be ruined.

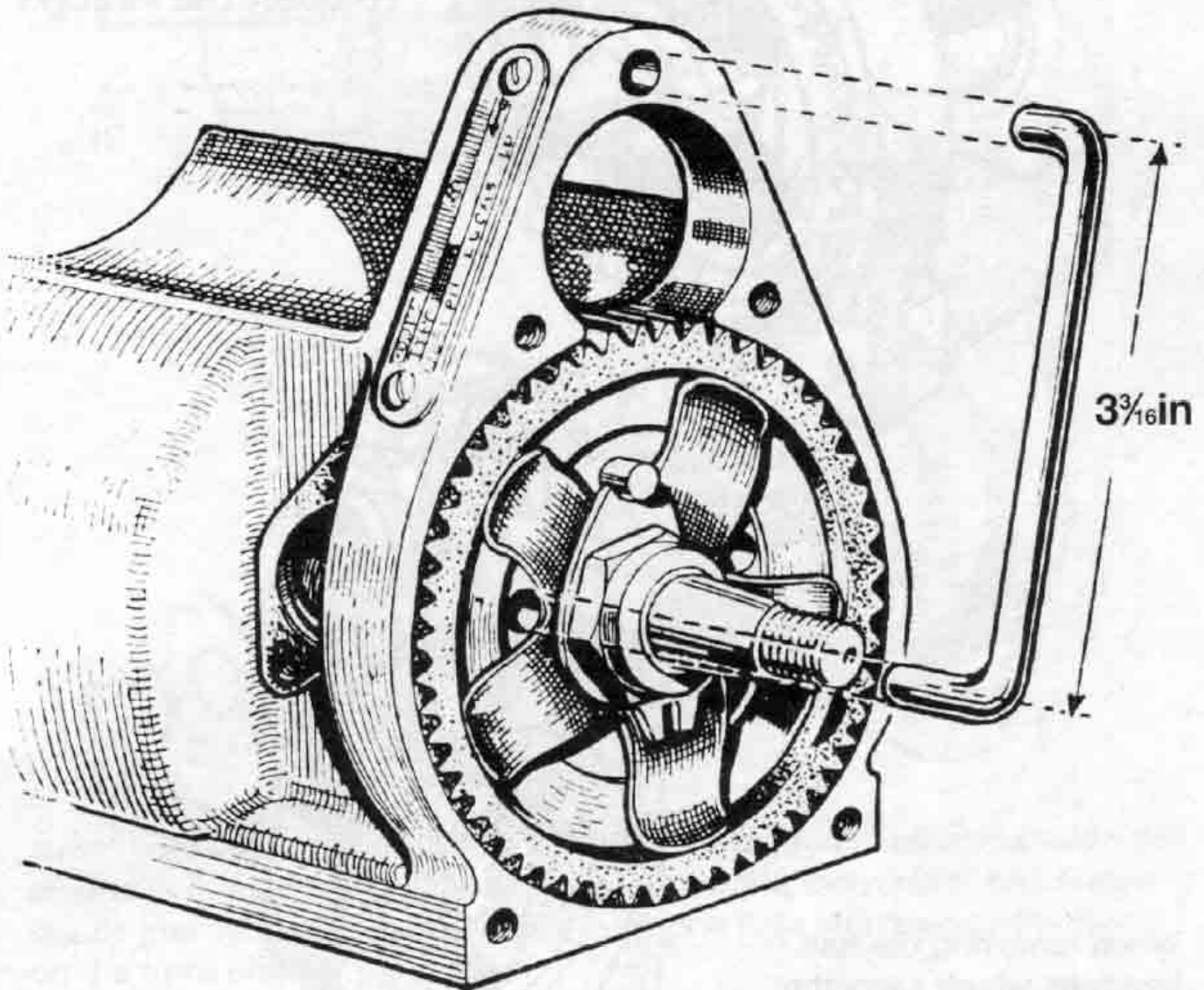

When dismantling the slipping clutch on the Lucas Magdyno a U-shaped tool will prove invaluable. Use $\frac{1}{4}$ in mild steel rod.

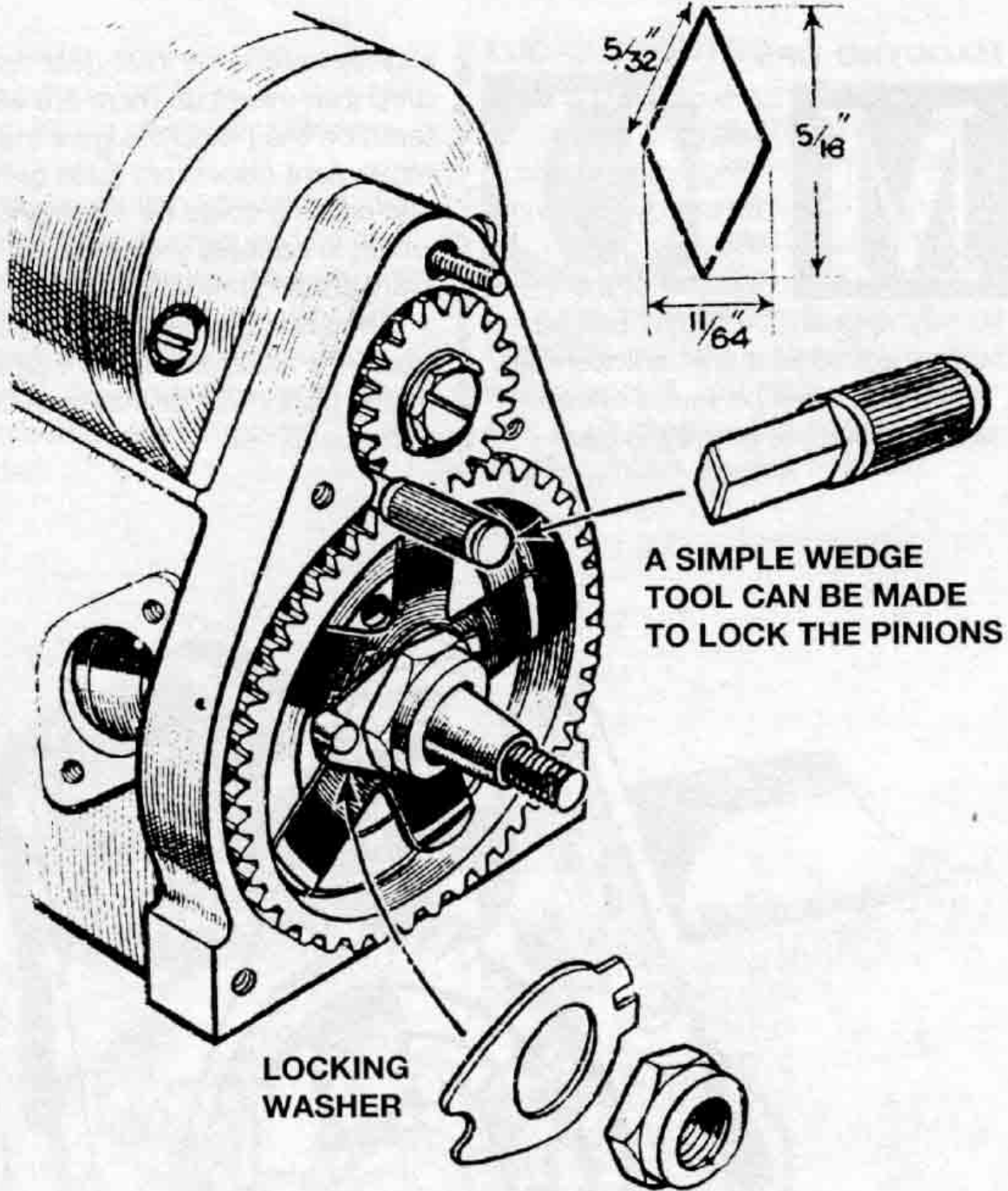

When removing the ball bearings which carry the armature, this tool makes a tricky job quite easy.

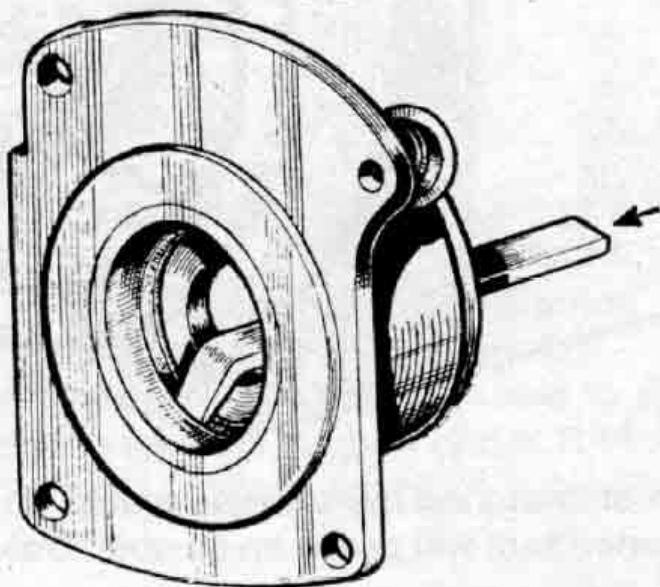

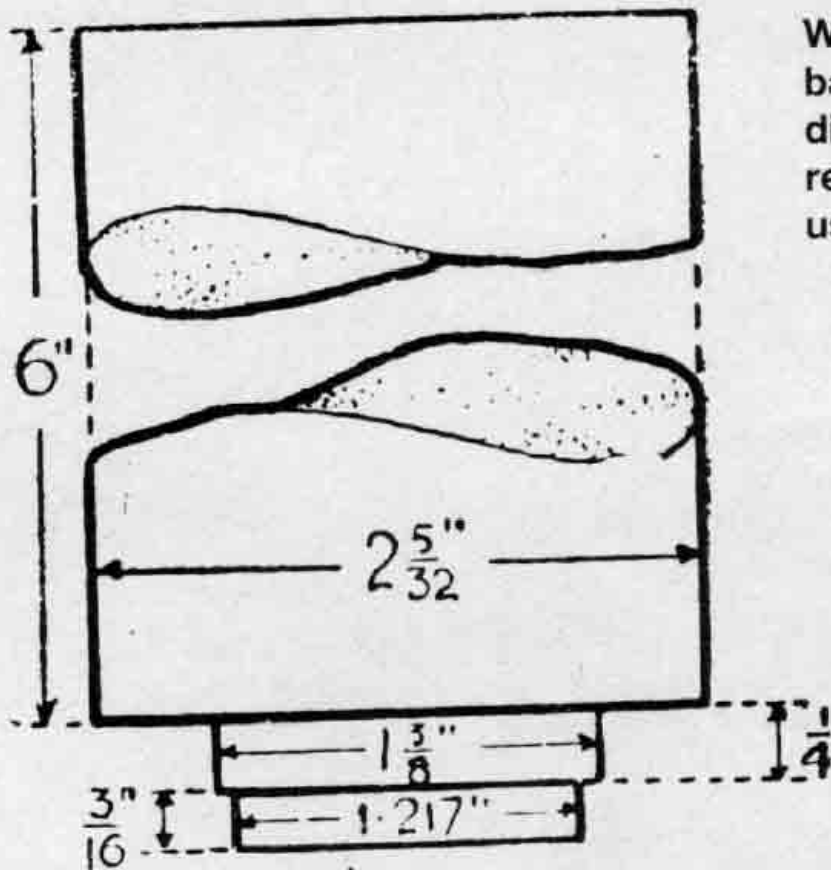

When replacing armature ball bearings a tool to these dimensions is recommended. It is best used in a hand press.

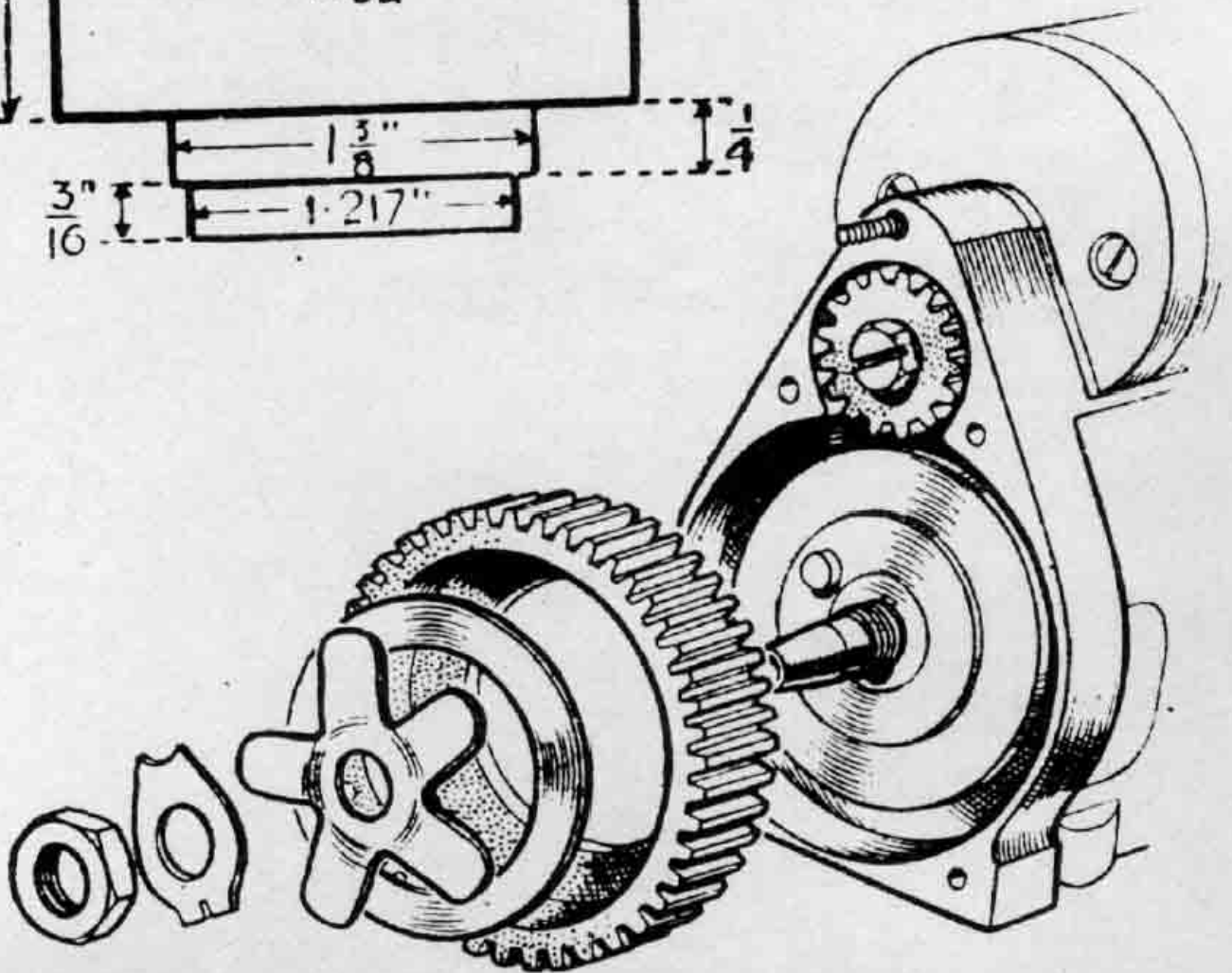

Avoid constant blipping of the throttle on Magdyno machines when the engine is in neutral. The dynamo portion of the instrument has considerable inertia, and rapid changes in engine revs will destroy the teeth on the fibre pinions.

Later Magdynos are fitted with a dynamo-driven clutch to prevent this. When reassembling the central locknut should be tightened to 10ft lbs to avoid clutch slip.

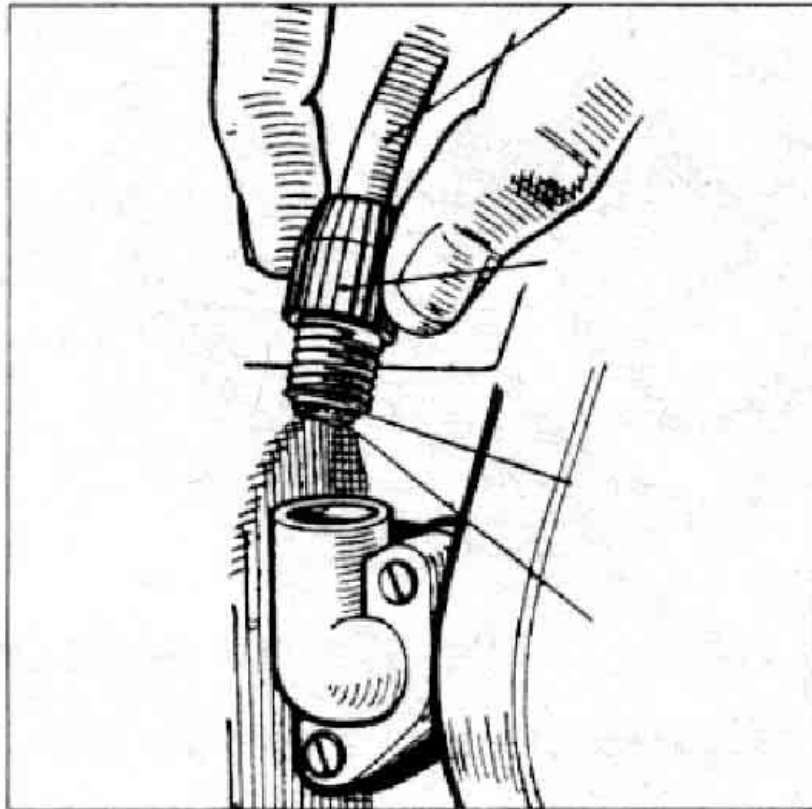

This booklet is presented free with

THE CLASSIC
MotorCycle