



REPLACEMENT PARTS CATALOGUE

FOR 1971

**BONNEVILLE T120R
TIGER 650 TR6R
TROPHY 650 TR6C**

TRIUMPH ENGINEERING COMPANY LIMITED

MERIDEN WORKS · ALLESLEY · COVENTRY CV5 9AU · ENGLAND

**TELEPHONE COVENTRY 20221
MERIDEN 331**

**TELEGRAMS "TRUSTY" COVENTRY
TELEX "TRUSTY" 31305**

INTRODUCTION

The Triumph Engineering Co. Ltd. point out that the information in this catalog was complete and correct at the time of printing. Distributors will be informed of any subsequent alterations.

A plastic binder, of the type used for Workshop Manuals, is available to enable this catalog and all other 1971 season catalogs to be bound into one unit.

GUARANTEE

Please refer to your dealer or distributor for the latest terms of guarantee.

Eastern U.S.A. Distributor:

Triumph Motorcycle Corporation,
P.O. Box 6790,
Towson,
Baltimore 4,
Maryland 21204.

Telex—Tricor Balt. 87728
Telephone—301-252-1700

Western U.S.A. Distributor:

Triumph Motorcycle Corporation,
P.O. Box 2765,
East Huntington Drive,
Duarte,
California 91010.

Telex—Tricor Duarte 675469
Telephone—213-359-3221
213-681-0255

ENGINE AND FRAME NUMBERS

The engine number is located on the left side of the engine, immediately below the cylinder barrel to crankcase flange.

The frame number is located on the left side of the frame headlug, beneath the fork top lug and forward of the gasoline tank.

Both the engine and frame number should be quoted in full in any correspondence relating to the machine.

INDEX

	<i>Page</i>		<i>Page</i>
AIR CLEANER	65	KICKSTARTER	37
ALTERNATOR	11, 41	MANIFOLD	17
AUTO-ADVANCE UNIT	31	MOTOR PLATES	47
BATTERY CARRIER	81	MOTOR TORQUE STAY	47
BRAKE SWITCHES	45	MUFFLERS	49, 51
BREATHER PIPES	43	OIL PUMP	17
CAMSHAFT, INLET AND EXHAUST	11	OIL PIPES	43
CARBURETOR	27, 29	OIL PRESSURE RELEASE VALVE	17
CARTON PACKS	7	PISTONS	11
CENTRE STAND	43	PROP STAND	43
CHAINS	41	PUSH RODS	19, 21, 23, 25
CHAINCASE	41	REAR WHEEL	61
CLUTCH	39	RECTIFIER	77
CLUTCH LEVER ASSEMBLY	37	ROCKERS	19, 21, 23, 25
COIL	77	SIDE PANEL	65
CONDENSER PACK	77	SPARK PLUG	77
CONNECTING RODS	11	SPEEDOMETER	75
CONTACT BREAKER	31	SPEEDOMETER GEARBOX	61
CONTROL CABLES	71	STEERING DAMPER	57
CONTROL LEVERS	69	SUSPENSION UNITS	45
CRANKCASE	13, 15	SWINGING FORK	45
CRANKCASE UNDERSHIELD	51	SWITCHES	69, 79
CRANKSHAFT	11	TABLE OF STANDARD HARDWARE	82
CYLINDERS	19, 21, 23, 25	TACHOMETER	75
CYLINDER HEAD	19, 21, 23, 25	TACHOMETER GEARBOX	75
EXHAUST PIPES	49, 51	TAIL LAMP	67
EXHAUST PIPE ADAPTOR	19, 21, 23, 25	TAPPETS	17
FENDERS	67	TIMING GEARS	11
FIVE SPEED GEARBOX	84	TOOLKIT	73
FLASHERS	77, 79	TWIN SEAT	63
FOOTRESTS	47, 51	VALVES	19, 21, 23, 25
FRAME	43	VALVE GUIDES	19, 21, 23, 25
FRONT FORKS	53, 55	WIRING HARNESS	79
FRONT WHEEL	59	ZENER DIODE...	77
FUSE ASSEMBLY	57		
GAS TANK	63		
GEARBOX	33, 35, 37		
HANDLEBAR	69		
HANDLEBAR MOUNTINGS	57		
HEADLAMP	79, 81		
HORN	77		



TIGER 650 (TR6R) TECHNICAL DATA

Bore and stroke...	71 x 82 mm. 2.79 x 3.23 ins.
Capacity	649 c.c. (40 cu. ins.)
Compression ratio	9 : 1
Spark plugs	Champion N3
Carburetor	Amal Concentric 930
										Main jet ... 230
										Needle jet106
										Throttle valve ... No. 3½
Gearbox sprocket	19 teeth
Chains	Front ... ⅜" Duplex x 84 links
										Rear ... ⅝" x ⅜" x 106 links
Capacities	Gas Tank ... 3.6 U.S. galls.
										Oil Tank ... 4.8 U.S. pints
										Gearbox ... ⅞ pint (500 c.c.)
										Primary Chaincase ... ¼ pint (150 c.c.)
										Front Forks (each leg) ... ⅓ pint (190 c.c.)
Brakes	Front, diameter... 8" (20.32 cm.)
										Rear, diameter ... 7" (17.78 cm.)
Tire size	Front ... 3.25 x 19
										Rear ... 4.00 x 18



TROPHY 650 (TR6C) TECHNICAL DATA

Bore and stroke...	71 x 82 mm. 2.79 x 3.23 ins.
Capacity	649 c.c. (40 cu. ins.)
Compression ratio	9 : 1
Spark plugs	Champion N3
Carburetor	Amal Concentric 930
				Main jet	230
				Needle jet106
				Throttle valve	No. 3½
Gearbox sprocket	18 teeth
Chains	Front	¾" Duplex x 84 links
				Rear	5/8" x 3/8" x 106 links
Capacities	Gas Tank	3.6 U.S. galls.
				Oil Tank	4.8 U.S. pints
				Gearbox	7/8 pint (500 c.c.)
				Primary Chaincase	¼ pint (150 c.c.)
				Front Forks (each leg)	1/3 pint (190 c.c.)
Brakes	Front, diameter...	8" (20.32 cm.)
				Rear, diameter	7" (17.78 cm.)
Tire size	Front	3.25 x 19
				Rear	4.00 x 18



BONNEVILLE (T120R) TECHNICAL DATA

Bore and stroke	71 x 82 mm. 2.79 x 3.23 ins.
Capacity	649 c.c. (40 cu. ins.)
Compression ratio	9 : 1
Spark plugs	Champion N3
Carburetors	2 Amal Concentric 930
										Main jet 190
										Needle jet106
										Throttle valve No. 3
Gearbox sprocket	19 teeth
Chains	Front $\frac{3}{8}$ " Duplex x 84 links
										Rear $\frac{5}{8}$ " x $\frac{3}{8}$ " x 106 links
Capacities	Gas Tank 3.6 U.S. galls.
										Oil Tank 4.8 U.S. pints
										Gearbox $\frac{7}{8}$ pint (500 c.c.)
										Primary Chaincase $\frac{1}{4}$ pint (150 c.c.)
										Front Forks (each leg) $\frac{1}{3}$ pint (190 c.c.)
Brakes	Front, diameter... .. 8" (20.32 cm.)
										Rear, diameter 7" (17.78 cm.)
Tire size	Front 3.25 x 19
										Rear 4.00 x 18

HOW TO USE THIS SPARE PARTS CATALOG

First consult the index on Page 3 for the parts or group of parts which you wish to locate. When you have located the parts make sure from the end columns that the part you have located does apply to your machine.

List the quantities required as single units; do not ask for "2 pairs" or "3 dozen".

In case of painted items always state the color required. Painted parts are available only in the colors or alternatives specified for that model of that particular year.

CARTON PACK LIST

The following sub-assemblies are supplied in carton packs under the C.P. part number stated. The contents of these carton packs are preserved and will not deteriorate under adverse conditions.

<i>Part No.</i>	<i>Contents</i>
Brake Lining	
C.P.38/A.M.2 2	NW243 Brake lining
... .. 16	W129 Rivet
C.P.205 2	W1734 Brake lining
... .. 16	W129 Rivet
Pistons (complete with rings, gudgeon pins and circlips)	
E6895	7.5 : 1 C.R. For use with low grade fuel
E9488	9 : 1 C.R. Standard
E6867	11 : 1 C.R. Competition use only
All the above pistons are available in oversizes of 0.010 ins., 0.020 ins., 0.040 ins., (0.25 mm., 0.5 mm., 1mm.)	
Valve Guides	
C.P.97 2	E2899 Inlet guide
(TR6) 2	E2900 Exhaust guide

PLEASE NOTE

THROUGHOUT THIS LIST, ASSEMBLIES ARE PRINTED IN CAPITALS AND THE COMPONENTS INCLUDED IN THAT ASSEMBLY ARE INDENTED IN THE DESCRIPTION COLUMN, REVERTING TO THE ORIGINAL ALIGNMENT WHEN THE ASSEMBLY IS COMPLETE. TO ORDER THE COMPLETE ASSEMBLY IT IS NECESSARY ONLY TO QUOTE THE ASSEMBLY NUMBER. ANY COMPONENT PARTS LISTED MAY ALSO BE OBTAINED SEPARATELY IF REQUIRED.

SPECIAL WORKSHOP TOOLS

A COMPLETE LIST OF WORKSHOP TOOLS CAN BE MADE AVAILABLE BY EITHER CONTACTING YOUR DEALER OR APPLYING DIRECT TO THE TRIUMPH SERVICE DEPARTMENT. IN MOST CASES THESE TOOLS ARE VERY COSTLY AS THEY ARE MADE ENTIRELY FOR WORKSHOP USE, AND THEREFORE, IT IS NOT RECOMMENDED THAT THE PRIVATE OWNER PURCHASES THE TOOLS IN ORDER TO AID SERVICING THE MACHINE ONCE OR TWICE ONLY. IN THESE CIRCUMSTANCES IT IS FAR MORE ECONOMICAL TO GET IN TOUCH WITH A RECOGNISED DEALER.

UNIFIED THREAD FORM

NEW PARTS HAVING THREADED FIXINGS INTRODUCED IN THIS CATALOG HAVE THE UNIFIED FORM OF SCREW THREADS. THIS CHANGEOVER WILL BE CONTINUED AS AND WHEN NEW PARTS ARE INTRODUCED. EVEN WHERE PARTS ARE SIMILAR IN APPEARANCE NEW PART NUMBERS WILL BE ALLOCATED TO IDENTIFY THE UNIFIED THREADS. ALL NUTS, BOLTS AND STUDS HAVING THIS THREAD ARE IDENTIFIED BY MARKINGS. BOLTS HAVE A CIRCULAR RECESS IN THEIR HEADS, STUDS A CIRCULAR GROOVE ON THE END, AND NUTS HAVE INTERLOCKING CIRCLES ON THE SIDE.

COLOR

TIGER 650 (TR6R)— }
TROPHY 650 (TR6C)— } Pacific Blue

BONNEVILLE (T120R)—Tiger Gold

Paint is available in aerosol containers only.

TRIUMPH SPARES

HOW TO ORDER. Every part is indicated by a number, and this should be quoted together with the description. In order to assist customers, dimensions have been given in many cases where parts are similar. Parts where possible have been listed in order of assembly and a number of the illustrations show the assembly order also. With these aids, there should be no difficulty in identifying the parts you require.

ALWAYS HEAD YOUR ORDER WITH THE ENGINE NUMBER, STAMPED ON THE LEFT SIDE OF THE ENGINE JUST BELOW THE CYLINDER, TOGETHER WITH THE PREFIX LETTERS.

WHERE TO OBTAIN. Triumph Spare Parts can only be obtained from an authorised Triumph Dealer, and we recommend our customers to place their orders with the Triumph Dealer in their district. When parts not usually asked for are required, and for which the Dealer may have to write or obtain specially, the postage or carriage incurred becomes payable.

TRIUMPH SPARES ARE NOT SUPPLIED TO PRIVATE OWNERS DIRECT FROM THE FACTORY. A LIST OF AUTHORISED DEALERS WHO STOCK TRIUMPH SPARES IS AVAILABLE ON REQUEST. IF DIFFICULTY IS EXPERIENCED IN OBTAINING THE REQUIRED PARTS, THE MATTER SHOULD BE TAKEN UP DIRECTLY WITH THE TRIUMPH SPARES DEPARTMENT.

Customers are warned against the risk incurred by purchasing parts that are not of genuine Triumph manufacture. This risk is eliminated if parts are ordered as instructed from recognised Dealers.

PATTERNS AND PARTS FOR REPAIR. It is not necessary to send patterns if the part number is quoted. The sending of patterns often delays the order as parcel post or rail takes longer than letter post.

Parts sent to Coventry for repair, replacement, or as patterns should bear the sender's Name and Address and clear instructions should accompany the parts. In your own interest send a copy of the advice note under separate cover. All parts must be forwarded carriage paid and care should be taken to ensure that all remittances are sent separately and not enclosed with the parts. Fragile units such as cylinders, etc., should always be boxed to avoid damage in transit. Complete machines should have all fitments such as windscreens, driving mirrors, tools, etc., removed by the sender before despatch, as it is impossible for us to accept responsibility in the event of loss in transit. We are always pleased to give estimates for overhauling and repairs, but should an estimate not be accepted, a charge will be made covering cost of dismantling and re-assembling, if carried out. Work cannot be accepted at the factory direct from private owners.

Communications relating to Parts should be addressed to the SPARES DEPARTMENT and for repairs, guarantee claims and technical advice to the SERVICE DEPARTMENT, Triumph Engineering Co. Ltd., Meriden Works, Allesley, Coventry. In order to facilitate quick reference, the quoting of any number, invoice number or reference from previous communications is essential. Accessories not of our manufacture should be sent direct to the actual makers, whose Names and Addresses appear below.

PROPRIETARY GROUP

Ancillary equipment which is fitted to our motor cycles is of the highest quality and is guaranteed by the manufacturers and not by ourselves. Any repairs or claims should be directed to the actual makers or their local agents who will always give owners every possible assistance. The following are the addresses of the various manufacturers:—

CARBURETORS

Messrs. Amal Ltd.,
Holdford Road,
Witton,
Birmingham, 6.

CHAINS.

Renold Chains Ltd.,
Wythenshawe,
Manchester.

ELECTRICAL EQUIPMENT.

Messrs. J. Lucas Ltd.,
Gt. Hampton Street,
Birmingham, 18.

TIRES.

Dunlop Rubber Co. Ltd.,
Fort Dunlop,
Birmingham, 24.

The Avon Rubber Co. Ltd.,
Melksham,
Wilts.

SPARK PLUGS.

Champion Sparking Plug Co. Ltd.,
Feltham,
Middlesex.

INSTRUMENTS.

Messrs. Smiths Industries Ltd.,
Cricklewood Works,
London, N.W.2.

SUSPENSION UNITS.

Messrs. Girling Ltd.,
Birmingham Road,
West Bromwich,
Staffordshire.

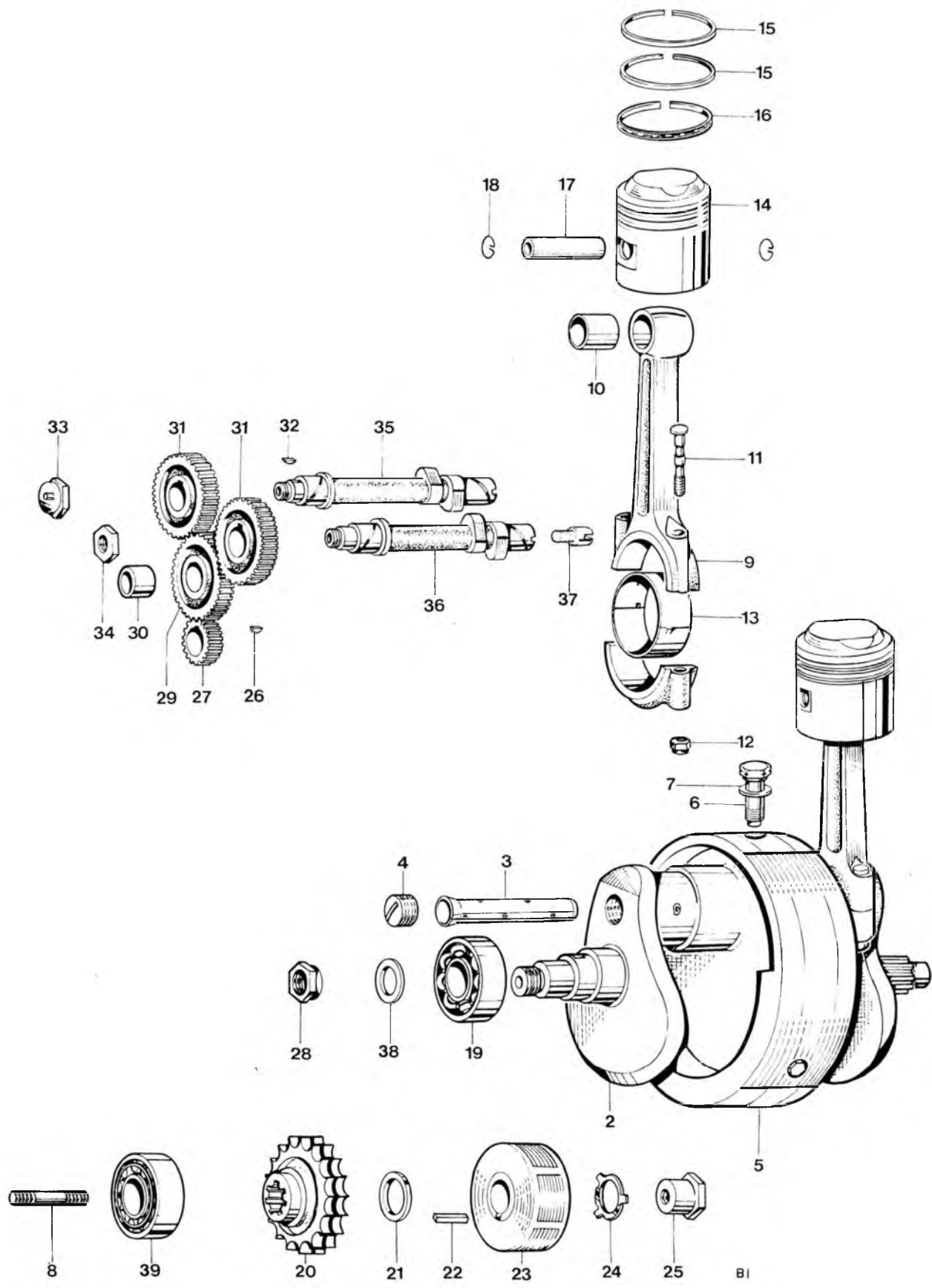

Fig. 1. CRANKSHAFT AND CONNECTING RODS

Ref. No.	Part No.	DESCRIPTION	QUANTITY	REMARKS
CRANKSHAFT AND CONNECTING RODS				
1	E12600	CRANKSHAFT AND FLYWHEEL ASSEMBLY	1	
2	E4643	CRANKSHAFT C/W. OIL TUBE	1	
3	E3903	Oil tube	1	
4	E3905	Screwed plug	1	
5	E12425	Flywheel	1	
6	E12601	Flywheel bolt	3	
7	E11003	Washer	3	
8	E3114	Crankshaft stud (1 $\frac{3}{8}$ in. O.A.)	1	
9	E9525	CONNECTING ROD	2	
10	E1511	Small end bush	2	
11	E6576	Connecting rod bolt	4	
12	S2016	Self locking nut	4	
13	E3586	Big end bearing (Available in —.010 in. and —.020 in. undersizes)	4	
14	E9488	PISTON COMPLETE 9 : 1 C.R.	2	
15	E6864	Taper compression ring	4	
16	E6865	Oil control ring	2	
17	E6861	Gudgeon pin (short)	2	
18	E6869	Circlip	4	
19	E1591	Main bearing, right	1	
20	E12662	Motor sprocket, 29 teeth Duplex	1	
21	E4573	Distance piece	1	
22	E100082	Rotor key	1	
23	54213901	Motor (99-0739)	1	
24	E3975	Tab washer	1	
25	E3977	Nut	1	
26	E1580	Key	1	
27	E4564	Timing pinion	1	
28	E4565	Nut	1	
29	E6159	INTERMEDIATE WHEEL	1	
30	E400	Intermediate wheel bush	1	
31	E12719	Camshaft wheel	2	
32	E1558	Camshaft key	2	
33	E11007	Inlet camshaft nut	1	
34	E6523	Exhaust camshaft nut	1	
35	E11063	Inlet camshaft,	1	
36	E9989	EXHAUST CAMSHAFT	1	
37	E9988	Tachometer drive plug	1	
38	E3300	Clamping washer	1	
39	E2879	Main bearing, left	1	
Not illus.	E12663	Spacer	1	
Not illus.	E8038	Shim (0.010 in.)		As required (up to 4)
Not illus.	E12660	Shim (0.030 in.)		As required (up to 4)

* Use D524 Loctite Sealant

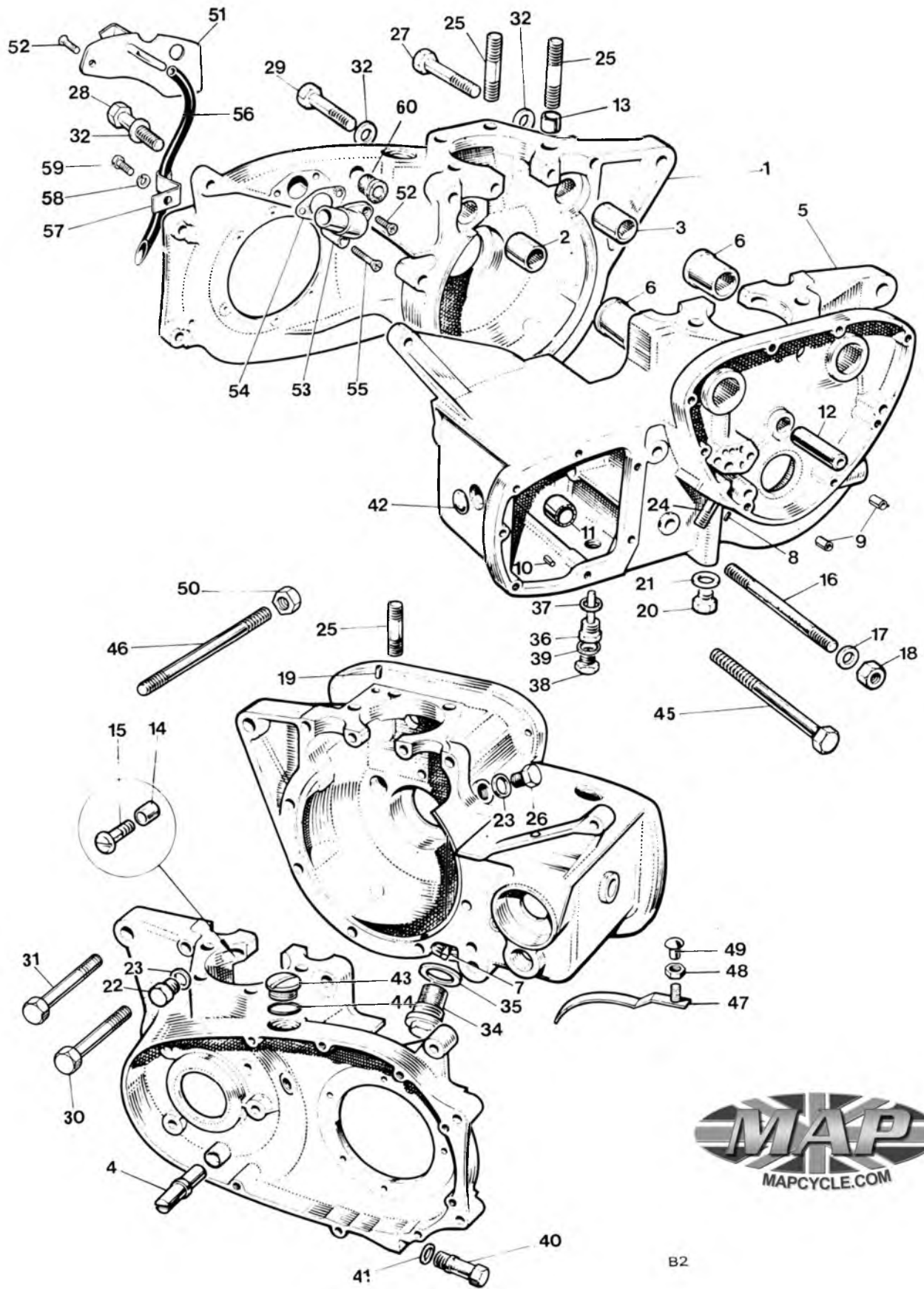

Fig. 2. CRANKCASE

Ref. No.	Part No.	DESCRIPTION	QUANTITY	REMARKS
CRANKCASE				
1	E11266	CRANKCASE DRIVE SIDE	1	
2	E10287	Camshaft bush	1	
3	E10287	Camshaft bush	1	
4	E5976	Chain tensioner abutment	1	
5	E12274	CRANKCASE TIMING SIDE	1	
6	E10286	Camshaft bush	2	
7	E4538	Scavenge pipe		Reference only
8	E6386	Locating peg (at oil pipes)		Reference only
9	T989	Hollow dowel	2	
10	T912	Locating peg (L/S at thrust washer)	1	
11	T1606	Needle roller bearing, layshaft	1	
12	E375	Intermediate wheel spindle	1	
13	E8751	Hollow dowel	1	
14	E3716	Hollow dowel	1	
15	S1873	Screw	2	
16	14-1445	Stud	1	
17	S25-2	Plain washer	2	
18	14-0303	Nut	2	
19	E1532	Hollow dowel, tappet oil feed	2	
20	E9330	Oilway plug	1	
21	F1880	Copper washer	1	
22	S1871	Tachometer drive plug (L.H. thread)	1	
23	E8896	Fibre washer	2	
24	S1863	Oil pipe stud	1	
25	S1865	Cylinder stud	8	
26	S1872	Plug, timing hole	1	
27	S1870	Bolt	1	
28	14-6220	Bolt	1	
29	14-6223	Bolt	1	
30	14-0230	Bolt	1	
31	S1823	Bolt	2	(TR6C 3 off)
32	D2330	Plain washer	10	(TR6C 7 off)
33	14-1302	Nut	5	(TR6C 4 off)
34	E9336	Crankcase filter	1	
35	E5315	Joint washer	1	
36	T2167	Drain plug (with level tube)	1	
37	T1257	Fibre washer	1	
38	S543	Level plug UN	1	
39	E2441	Copper washer	1	
40	T2259	Drain and adjuster plug	1	
41	T1738	Fibre washer	1	
42	T1920	Blanking plug	1	
43	T2166	Filler plug UN	2	
44	E8782	"O" ring	2	
45	14-6242	Bolt	1	
46	S669	Stud	1	(Except TR6C)
47	E8892	Protection blade	1	
48	14-1301	Self locknut UN	1	
49	E7573	Rubber plug (for protection blade stud hole)	1	
50	14-0402	Nut, exhaust ties	2	(Except TR6C)
51	E11072	Breather cover plate assembly	1	
52	E11075	Screw	1	

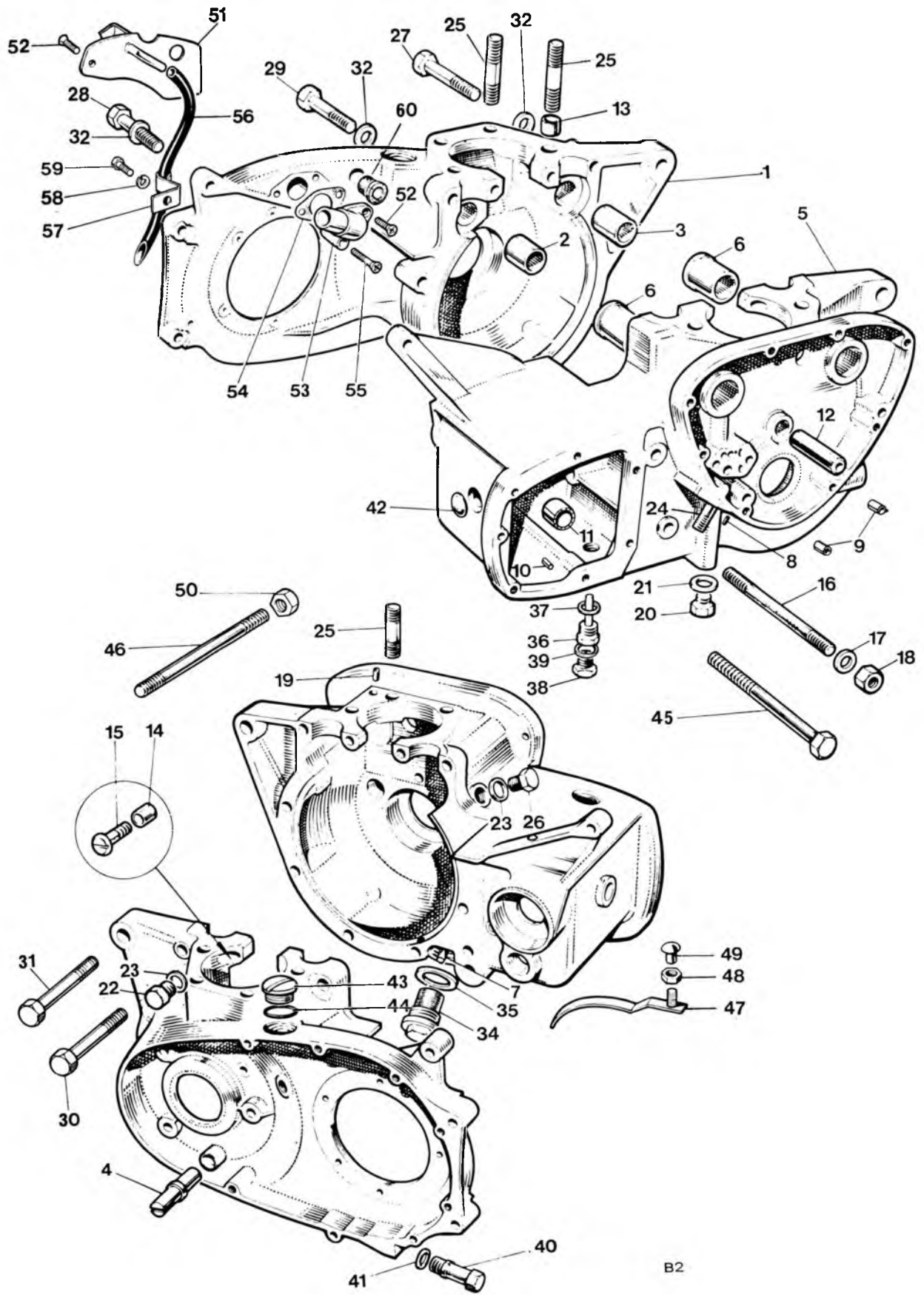

Fig. 2 CRANKCASE

Ref. No.	Part No.	DESCRIPTION	QUANTITY	REMARKS
----------	----------	-------------	----------	---------

CRANKCASE (continued)

53	E9335	Outlet stub	1	
54	E11460	Joint washer	1	
55	E11077	Screw	2	
56	E11078	Tube, primary chain oiler	1	
57	E4705	Clip	1	
58	S26-2	Spring washer	1	
59	14-0101	Bolt ($\frac{7}{16}$ in. U.H.)	1	
60	E11345	Grommet, alternator leads—external	1	

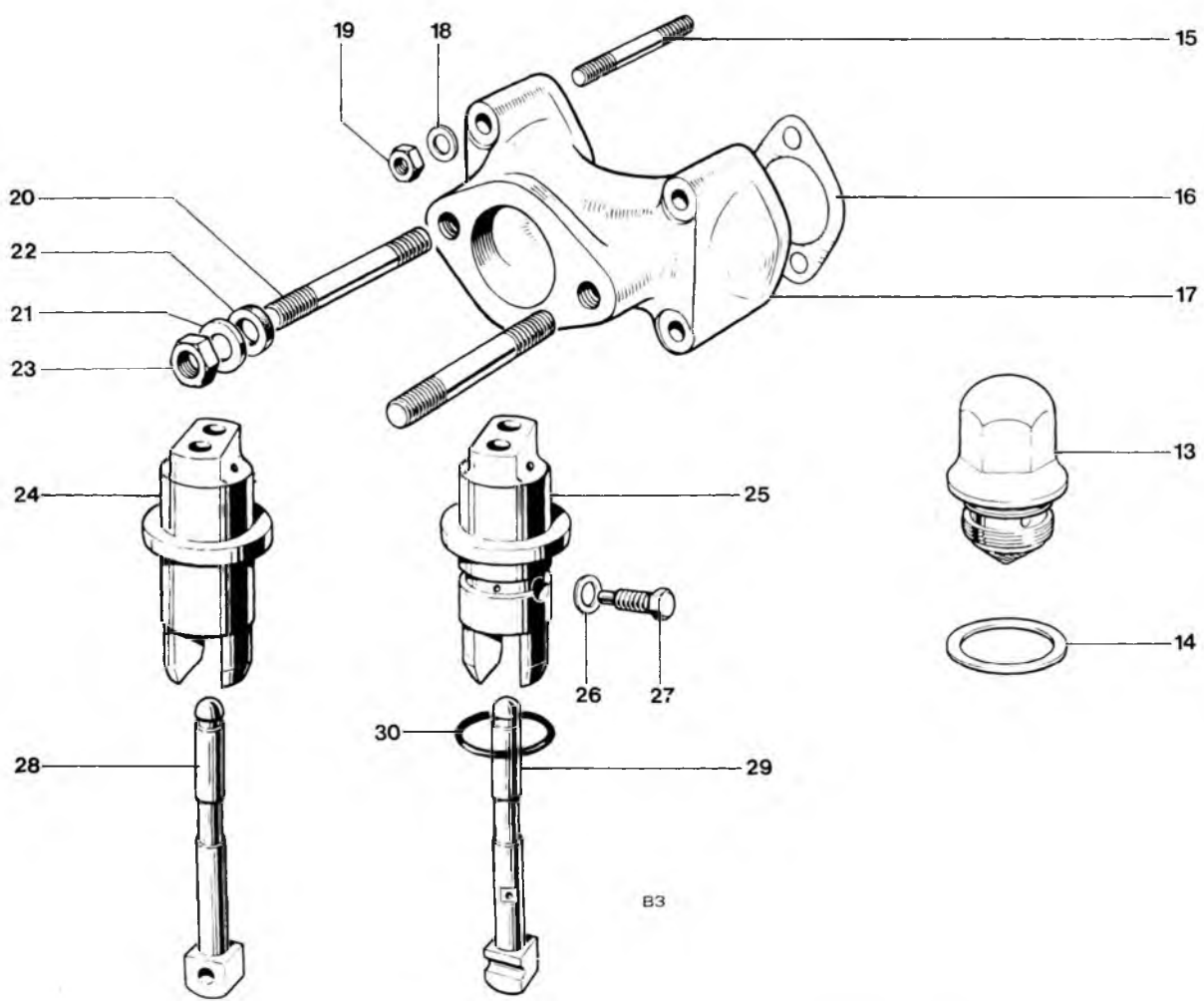
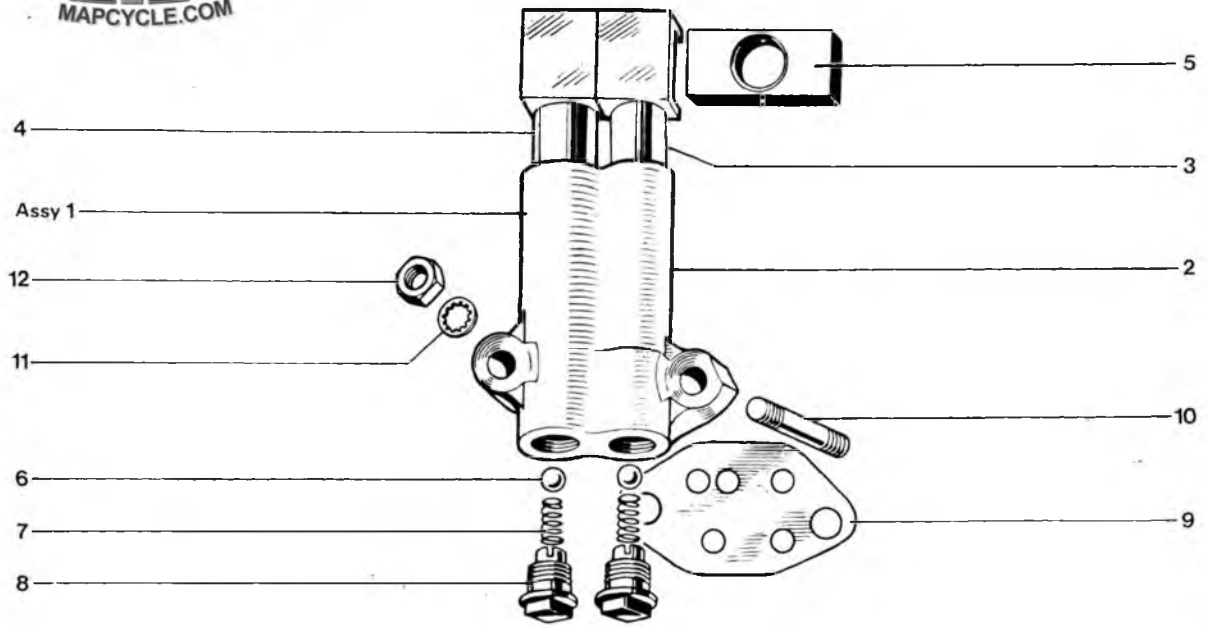

Fig. 3. OIL PUMP, RELEASE VALVE, MANIFOLD AND TAPPETS

Ref. No.	Part No.	DESCRIPTION	QUANTITY	REMARKS
----------	----------	-------------	----------	---------

OIL PUMP, RELEASE VALVE, MANIFOLD AND TAPPETS

1	E9421	OIL PUMP	1	
2	Reference only	Pump body	1	
3	E9269	Feed plunger	1	
4	E6681	Scavenge plunger	1	
5	E495	Drive block	1	
6	S70-7	Valve ball ($\frac{7}{32}$ in. dia.)	2	
7	E403	Valve spring	2	
8	E2360	Screwed plug	2	
9	E11461	Joint washer	1	
10	S1684	Oil pump stud	2	
11	E3887	Serrated washer	2	
12	S1906	Nut	2	
13	E12210	Oil release valve	1	
14	E1670	Fibre washer	1	
15	S1876	Stud	4	
16	E5660	Joint washer	2	
17	E9973	Inlet manifold	1	
18	S25-13	Plain washer	4	
19	S1877	Nut	4	
20	S1996	Stud	2	
21	E9555	Cup	2	
22	E9554	"O" ring	2	
23	14-1301	Nut	2	
24	E9352	Inlet tappet guide	1	
25	E9353	Exhaust tappet guide	1	
26	E1612	Copper washer	2	
27	H200	Set bolt	2	
28	E3059R	Inlet tappet	2	
29	E8801	Exhaust tappet	2	
30	E7563	'O' Ring	2	

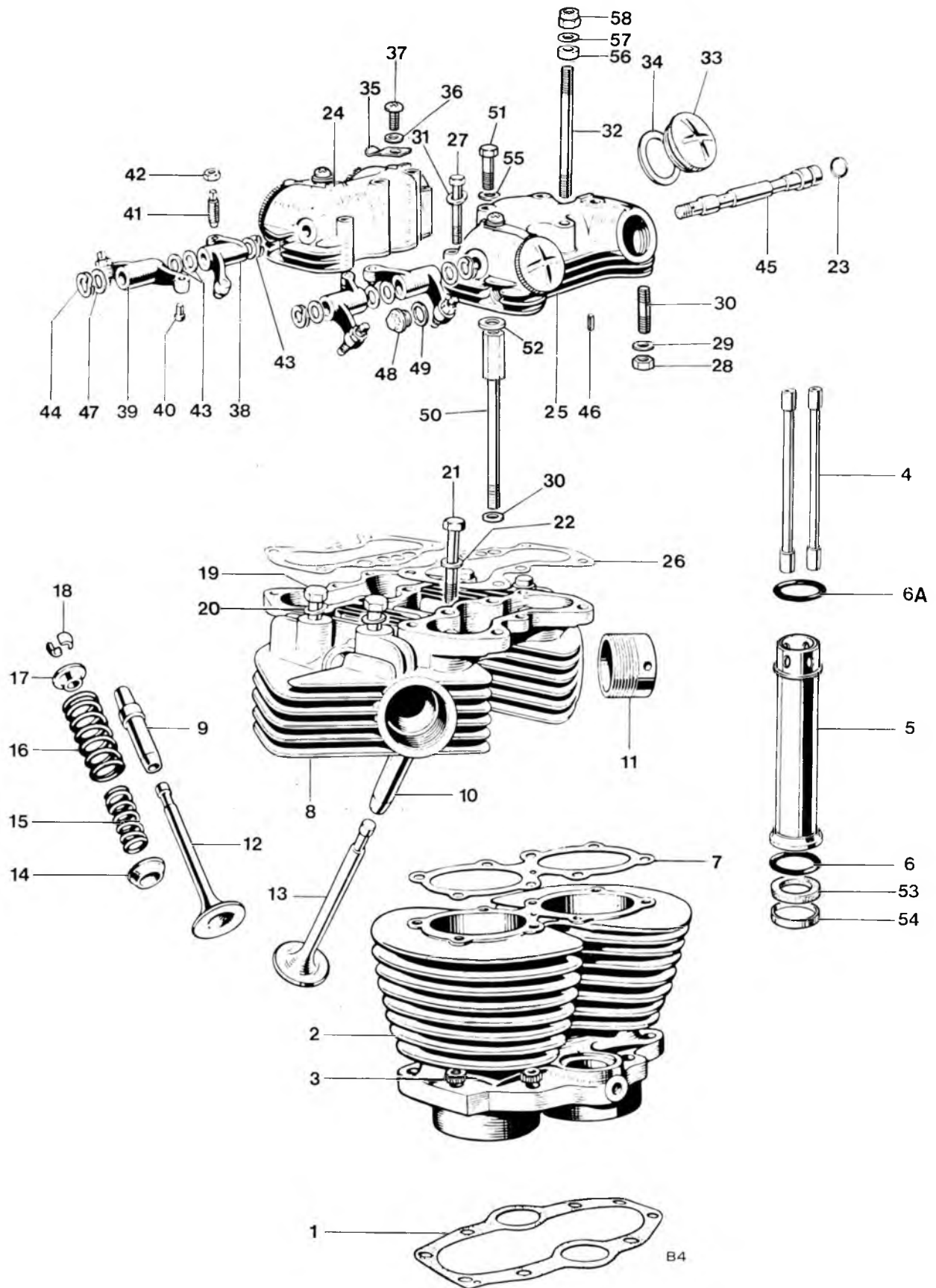

Fig. 4. CYLINDER BLOCK AND HEAD, TR6R, TR6C

CYLINDER BLOCK AND HEAD, TR6R, TR6C

1	E6309	Cylinder base washer	1	
2	E6304	Cylinder block	1	
3	S692	Cylinder base nut	8	
4	E2620	Push rod	4	
5	E12575	Cover tube	2	
6	E7310	"O" ring, push rod cover tube (bottom)	2	
6a	E11283	"O" ring, push rod cover tube (top)	2	
7	E4547	Cylinder head gasket	1	
8	E12354	CYLINDER HEAD c/w GUIDES	1	
9	E2899 71-3292	Inlet valve guide	2	
10	E2900 71-3293	Exhaust valve guide	2	
11	E9516	Exhaust pipe adaptor	2	
12	E4603	Inlet valve	2	
13	E2904	Exhaust valve	2	
14	E6439	Bottom cup	4	
15	E4221	Inner valve spring (red spot)	4	
16	E7400	Outer valve spring (green spot)	4	
17	E1543	Top collar	4	
18	99-0063 71-3748	Split cotter	8	
19	E327	Cylinder head bolt	4	
20	F2184	Plain washer	4	
21	E4771	Bolt	1	
22	S25-3 60-4247	Plain washer	1	
23	E3253 60-3548	Sealing ring	2	
24	E12350	Inlet rocker box	1	
25	E12351	Exhaust rocker box	1	
26	E12599	Joint washer	2	
27	S1875	Rocker box bolt	4	
28	14-0301	Rocker box nut... ..	6	
29	E3302	Plain washer	6	
30	14-1401	Rocker box stud	6	
31	S25-13 60-4248	Plain washer	4	
32	14-1435	Cylinder head stud (for torque stay)	2	
33	E4610 71-2744	Inspection cap	4	
34	E3751	Joint washer	4	
35	E4609	Locking spring	4	
36	WE170 60-4263	Fibre washer	4	
37	14-2203	Screw	4	
38	E1457	ROCKER (right exhaust, left inlet)	2	
39	E1458	ROCKER (left exhaust, right inlet)	2	
40	E10070	Rocker ball pin	4	
41	E1513	Rocker adjusting pin	4	
42	E470	Adjuster lock nut	4	
43	E1575	Thrust washer, 1/2 in.	6	
44	E1574	Spring washer	4	
45	E1512	Rocker spindle	2	
46	E12361	Dowel, rocker box	4	
47	E1330	Thrust washer, 3/8 in.	2	
48	E12079	Access plug	4	
49	E12080	Washer	4	
50	E12362	Bolt, cylinder head	4	
51	S588	Bolt, rocker box	4	

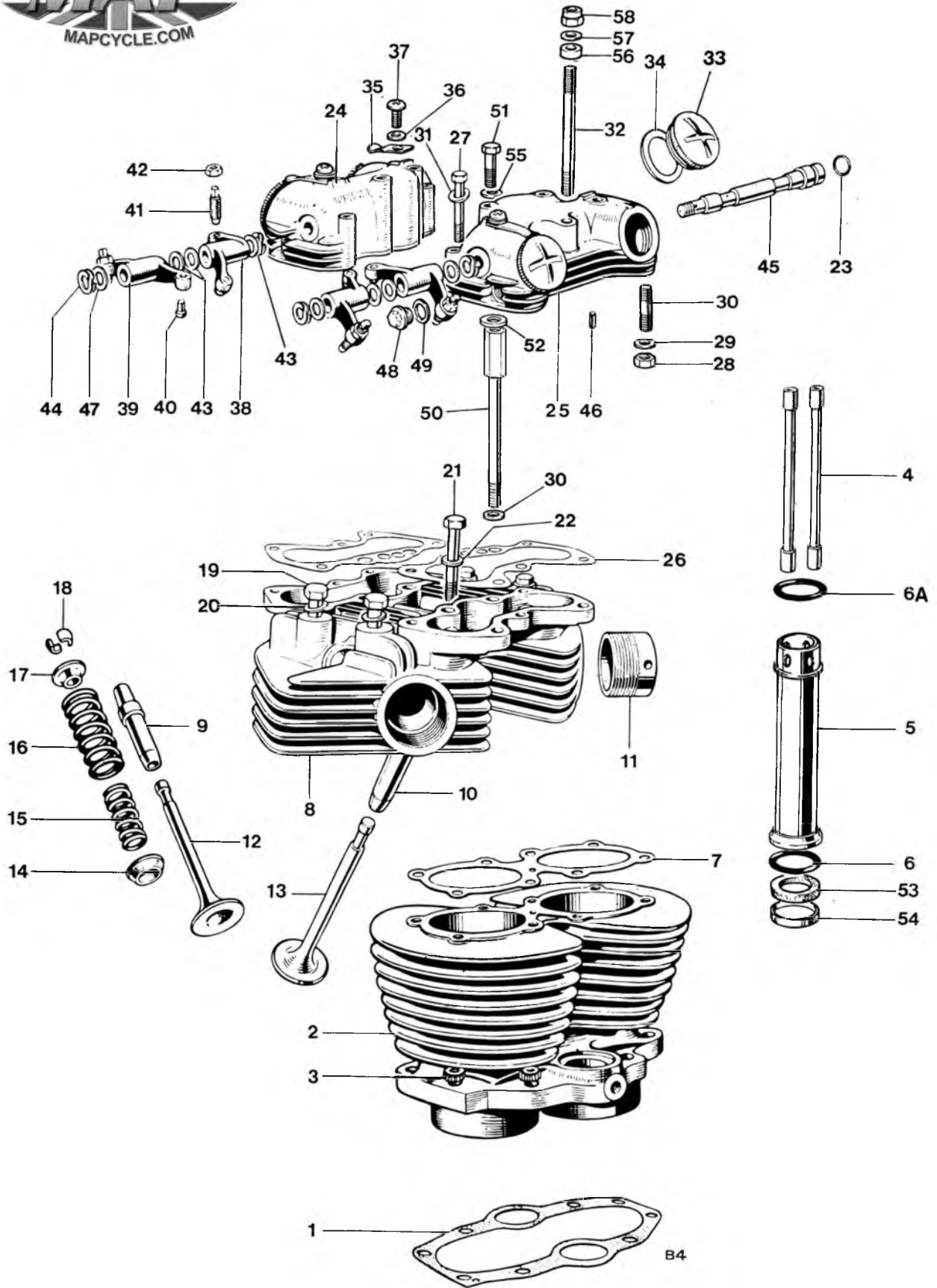
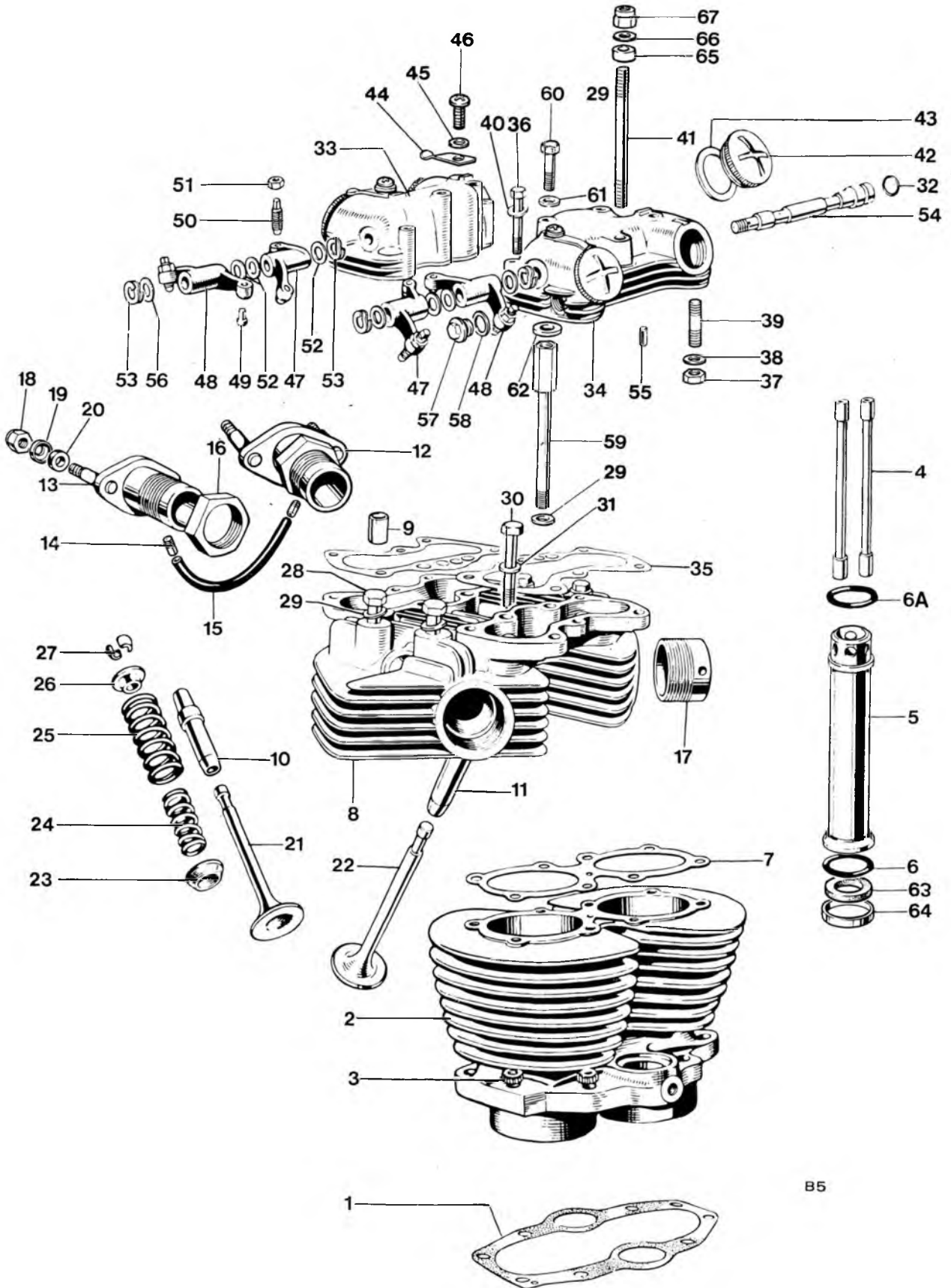

Fig. 4. CYLINDER BLOCK AND HEAD, TR6R, TR6C

Ref. No.	Part No.	DESCRIPTION	QUANTITY	REMARKS
----------	----------	-------------	----------	---------

CYLINDER BLOCK AND HEAD, TR6R, TR6C (continued)

52	E12598	Spacer	4	
53	E4752	Sealing ring	2	
54	E11707	Sleeve	2	
55	D2332	Washer	4	
56	E12597	Distance piece	2	
57	D2331	Washer	2	
58	14-1303	Nut	2	



B5

Fig. 5. CYLINDER BLOCK AND HEAD, T120R

Ref. No.	Part No.	DESCRIPTION	QUANTITY	REMARKS
CYLINDER BLOCK AND HEAD, T120R				
1	E6309	Cylinder base washer	1	
2	E6304	Cylinder block	1	
3	S692	Cylinder base nut	8	
4	E2620	Push rod	4	
5	E12575	Cover tube	2	
6	E7310	"O" ring (bottom)	2	
6A	E11283	"O" ring (top)	2	
7	E4547	Cylinder head gasket	1	
8	E12356	CYLINDER HEAD c/w GUIDES	1	
9	E5347	Sleeve for head bolts passing through inlet tracts		Reference only
10	E3827	Inlet valve guide	2	
11	E3828	Exhaust valve guide	2	
12	E9550	Carburetor adaptor, left	1	
13	E9551	Carburetor adaptor, right	1	
14	E6916	Connector	2	
15	E4792	Balance pipe	1	
16	S1932	Adaptor locking nut	2	
17	E9516	Exhaust pipe adaptor	2	
18	14-1301	Self-locking nut	4	
19	E9555	Cup	4	
20	E9554	Insulating ring	4	
21	E4603	Inlet valve	2	
22	E2904	Exhaust valve	2	
23	E6439	Bottom cup	4	
24	E4221	Inner valve spring (Red spot)	4	
25	E7400	Outer valve spring (green spot)	4	
26	E1543	Top collar	4	
27	99-0062	Split cotter	8	
28	E327	Cylinder head bolt	4	
29	F2184	Plain washer	4	
30	E4771	Bolt	1	
31	S25-3	Plain washer	1	
32	E3253	Sealing ring	2	
33	E12350	Inlet rocker box	1	
34	E12351	Exhaust rocker box	1	
35	E12365	Joint washer	2	
36	S1875	Rocker box bolt	4	
37	14-0301	Nut	6	
38	E3302	Plain washer	6	
39	14-1401	Rocker box stud	6	
40	S25-13	Plain washer	4	
41	14-1435	Cylinder head stud (for torque stay)	2	
42	E4610	Inspection cap	4	
43	E3751	Joint washer	4	
44	E4609	Locking spring	4	
45	WE170	Fibre washer	4	
46	14-2203	Screw	4	
47	E1457	ROCKER (right exhaust, left inlet)	2	
48	E1458	ROCKER (left exhaust, right inlet)	2	
49	E10070	Rocker ball pin	4	
50	E1513	Rocker adjusting pin	4	
51	E470	Adjuster lock nut	4	
52	E1575	Thrust washer, ½ in.	6	
53	E1574	Spring washer	4	

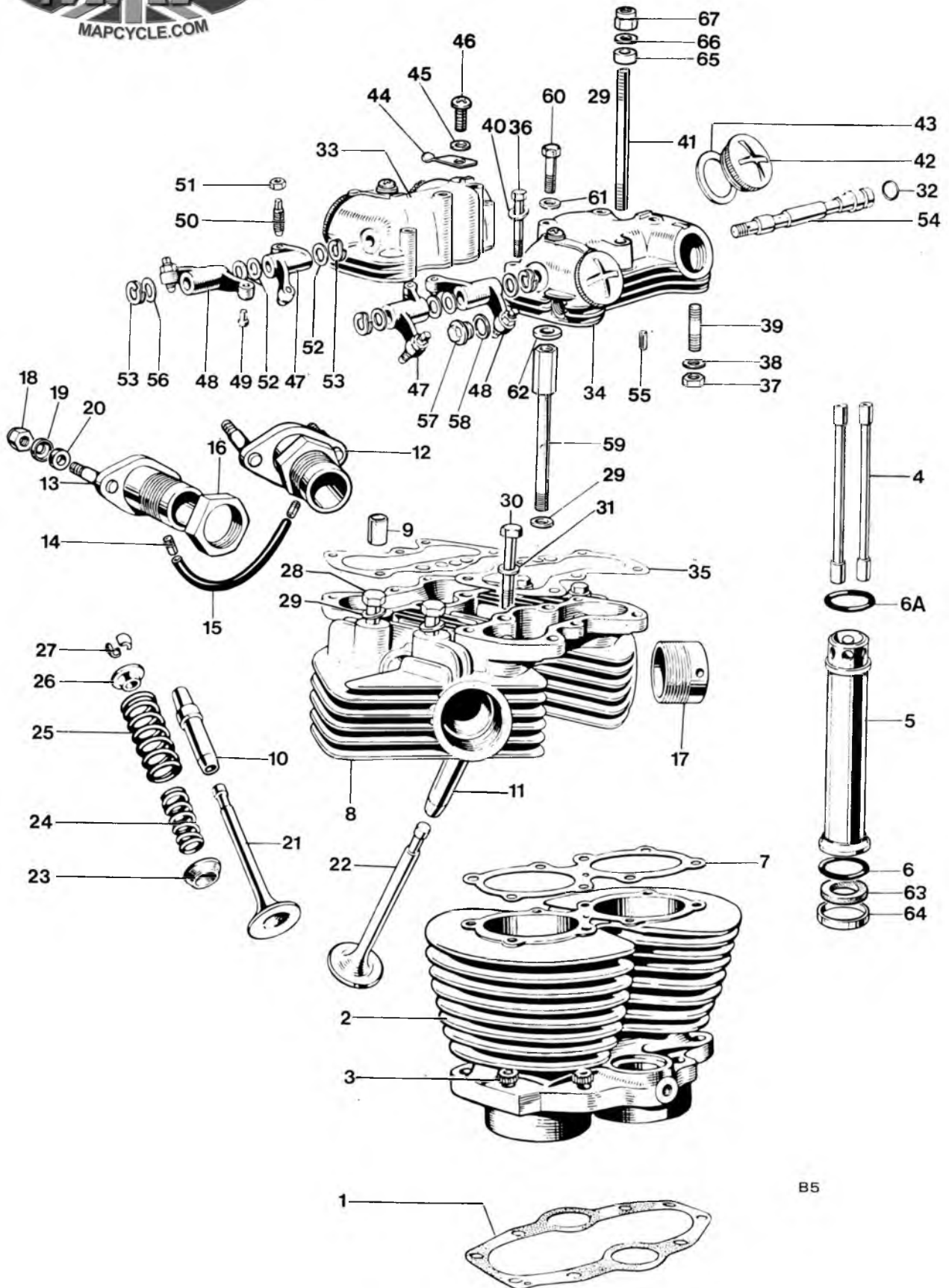

B5

Fig. 5. CYLINDER BLOCK AND HEAD, T120R

Ref. No.	Part No.	DESCRIPTION	QUANTITY	REMARKS
----------	----------	-------------	----------	---------

CYLINDER BLOCK AND HEAD, T120R (continued)

54	E1512	Rocker spindle	2	
55	E12361	Dowel, rocker box	4	
56	E1330	Thrust washer, $\frac{3}{8}$ in.	2	
57	E12079	Access plug	4	
58	E12080	Washer	4	
59	E12362	Bolt, cylinder head	4	
60	S588	Bolt, rocker box	4	
61	D2332	Washer	4	
62	E12598	Spacer	4	
63	E4752	Sealing ring	2	
64	E11707	Sleeve	2	
65	E12597	Distance piece	2	
66	D2331	Washer	2	
67	14-1303	Nut	2	

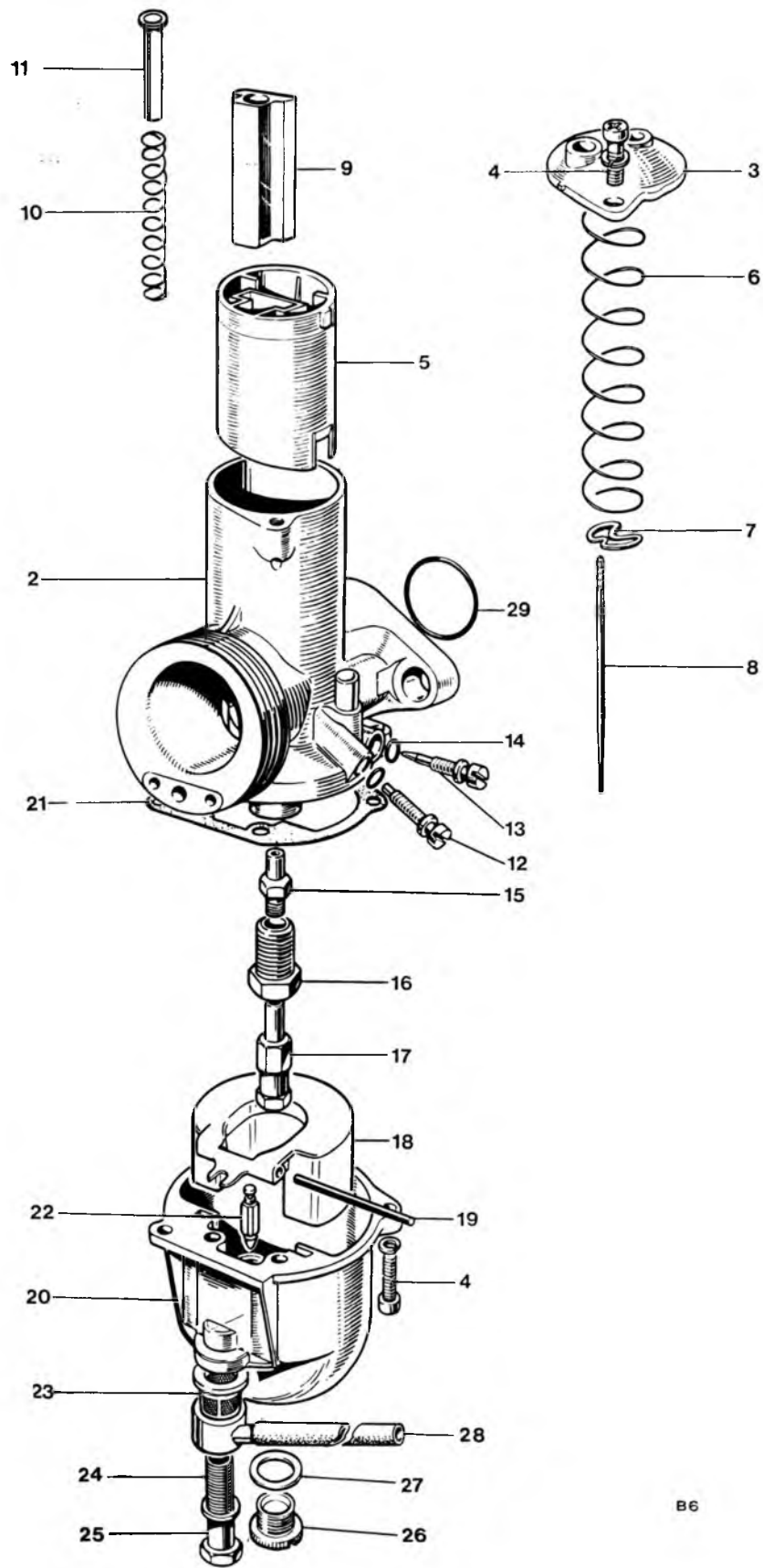

B6

Fig. 6. AMAL CARBURETOR, TR6R, TR6C

Ref. No.	Part No.	DESCRIPTION	QUANTITY	REMARKS
----------	----------	-------------	----------	---------

AMAL CARBURETOR TR6R, TR6C

1	D2183	CARBURETOR (R930/60) less "O" ring	1	
2	Reference only	Mixing chamber (930/005)	1	
3	928/098	Mixing chamber top (99-1032)	1	
4	622/086	Screw (99-0521)	4	
5	928/060	Throttle valve (3½ cutaway) (99-0527)	1	
6	622/131	Throttle return spring (99-1033)	1	
7	622/067	Needle clip (99-0510)	1	
8	622/124	Needle (99-1036)	1	
9	928/062	Air slide (99-0528)	1	
10	622/129	Spring (99-1038)	1	
11	928/103	Air valve guide sleeve (99-1037)	1	
12	622/077	Throttle stop screw (99-0516)	1	
13	622/076	Air adjusting screw (99-0515)	1	
14	622/082	"O" ring (99-0520)	2	
15	622/122	Needle jet (0-106) (99-1035)	1	
16	622/128	Jet holder (99-1034)	1	
17	376/100	Main jet (230) (99-0441)	1	
18	622/069	Float (99-0512)	1	
19	622/071	Float spindle (99-0513)	1	
20	622/055	Float chamber (99-0506)	1	
21	622/073	Joint washer (99-0514)	1	
22	622/068	Needle (99-0511)	1	
23	376/093	Filter (99-0438)	1	
24	622/078	Banjo bolt (99-0517)	1	
25	376/092	Fibre washer (99-0437)	1	
26	622/147	Drain plug (99-1152)	1	
27	622/151	Washer (99-1153)	1	
28	F13507	Petrol pipe	1	
29	E9711	"O" ring	1	

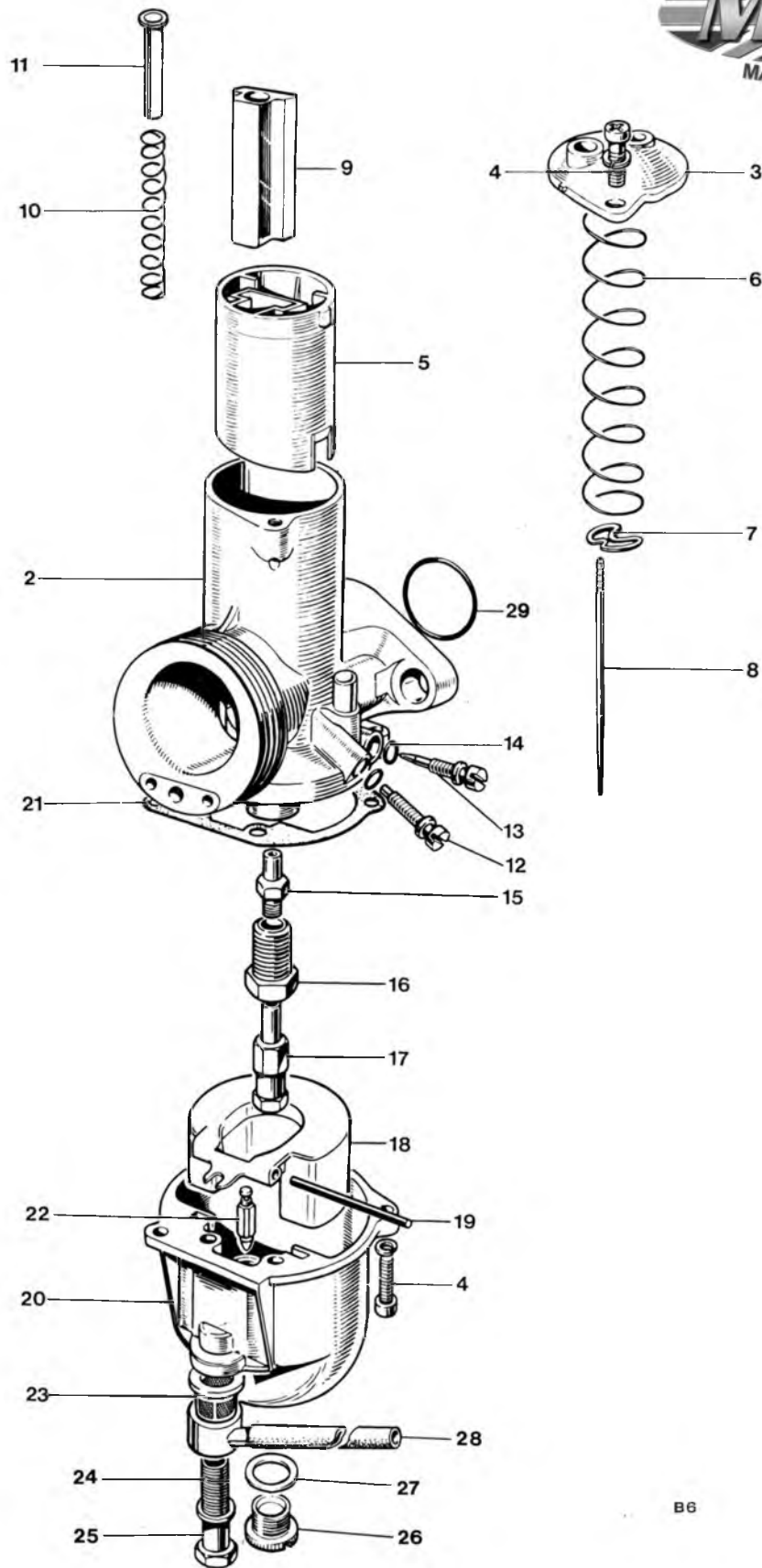

B6

Fig. 7. AMAL CARBURETOR, T120R

AMAL CARBURETOR T120R

1	D3492	CARBURETOR—L.H. (L930/67)	} Less "O" ring	1
1	D3491	CARBURETOR—R.H. (R930/66)		1
2	Reference only	Mixing chamber (L930/005 and R930/005)		1
3	928/098	Mixing chamber top (99-1032)		1
4	622/086	Screw (99-0521)		4
5	928/060	Throttle valve (3 cutaway) (99-0527)		1
6	622/131	Throttle return spring (99-1033)		1
7	622/067	Needle clip (99-0510)		1
8	622/124	Needle (99-1036)		1
9	928/062	Air slide (99-0528)		1
10	622/129	Spring (99-1038)		1
11	928/103	Air valve guide sleeve (99-1037)		1
12	622/077	Throttle stop screw (99-0516)		1
13	622/076	Air adjusting screw (99-0515)		1
14	622/082	"O" ring (99-0520)		2
15	622/122	Needle jet (0-106) (99-1035)		1
16	622/128	Jet holder (99-1034)		1
17	376/100	Main jet (190) (99-0446)		1
18	622/069	Float (99-0512)		1
19	622/071	Float spindle (99-0513)		1
20	622/055	Float chamber (99-0506)		1
21	622/073	Joint washer (99-0514)		1
22	622/068	Needle (99-0511)		1
23	376/093	Filter (99-0438)		1
24	622/078	Banjo bolt (99-0517)		1
25	376/092	Fibre washer (99-0437)		1
26	622/147	Drain plug (99-1152)		1
27	622/151	Washer (99-1153)		1
28	F13508	Petrol pipe		1
29	E9711	"O" ring		2

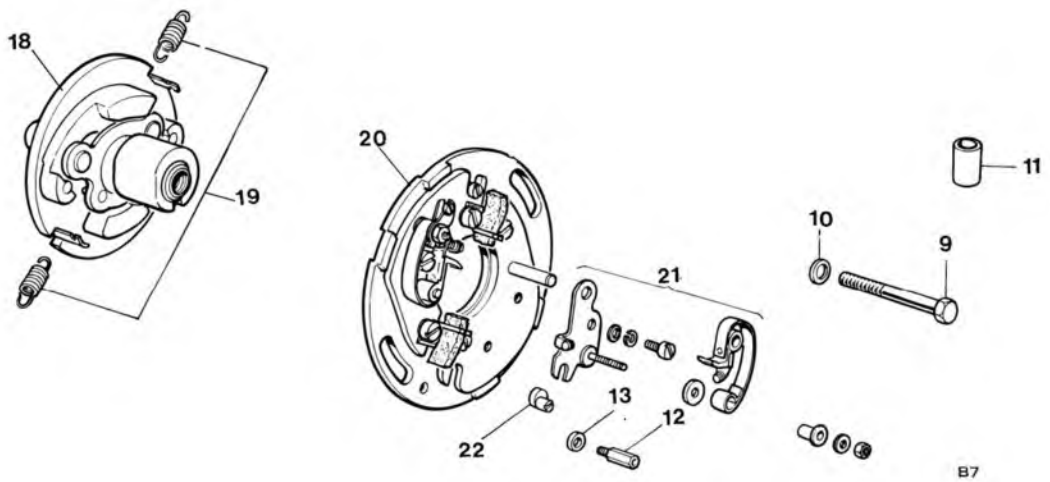
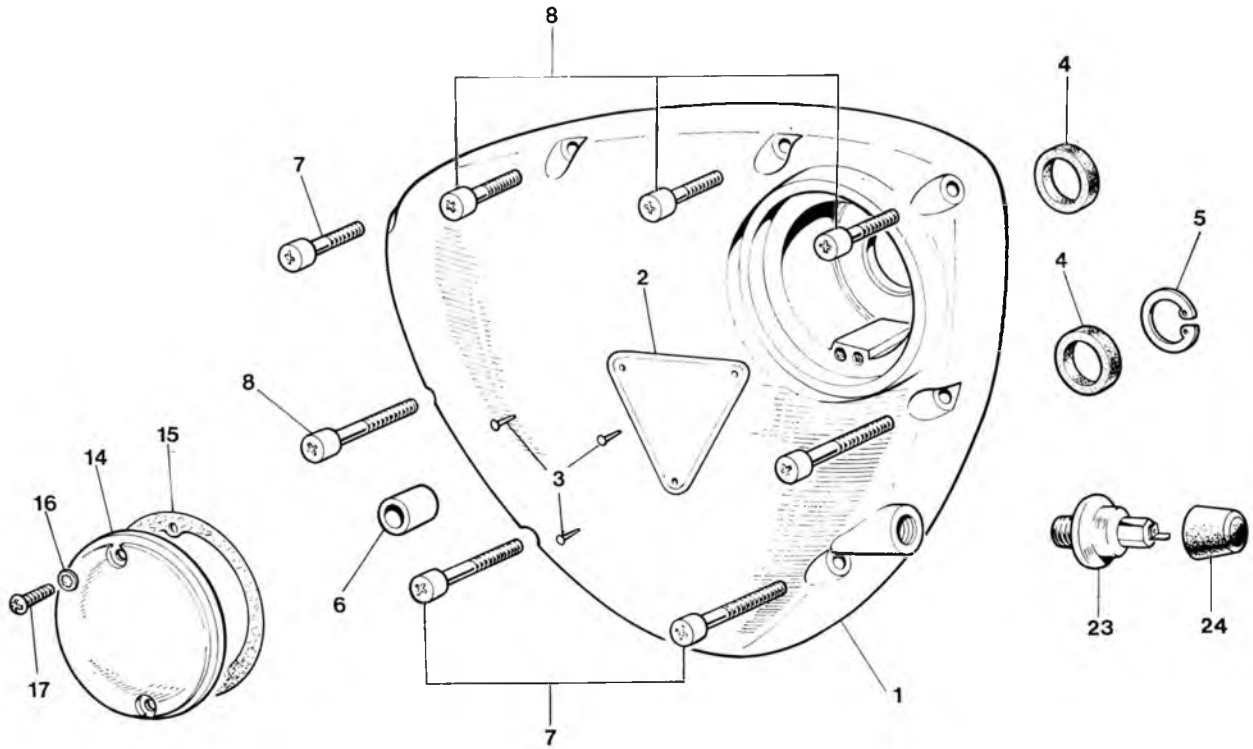

Fig. 8. TIMING COVER AND CONTACT BREAKER

Ref. No.	Part No.	DESCRIPTION	QUANTITY	REMARKS
----------	----------	-------------	----------	---------

TIMING COVER AND CONTACT BREAKER

1	E9246	Timing cover	1	
2	E4016	Patent plate	1	
3	D208-5	Hammer-drive screw	3	
4	E4568	Oil seal	2	
4	E6387	Oil seal (0.020 in. undersize)		For reground crankshaft
5	E4569	Circlip	1	
6	T989	Hollow dowel	1	
7	14-6609	Screw	3	
8	14-6608	Screw	5	
9	14-0208	Bolt	1	
10	S25-43	Plain washer	1	
11	E4707	Rubber grommet	1	
12	E7680	Pillar bolt	2	
13	E6559	Plain washer	2	
14	E8737	Cover	1	
15	E11462	Joint washer	1	
16	GS299	Serrated washer	2	
17	E7354	Screw (½ in. U.H.)	2	
18	54419340	AUTO ADVANCE UNIT (99-0771)	1	
19	54415642	Spring set (99-0757)	1	
20	54419097	CONTACT BREAKER PLATE ASSEMBLY (99-0768)	1	
21	54419827	Contact set (99-0772)	2	
22	54419220	Pin, adjustment (99-076y)	2	
23	D2133	Oil pressure switch	1	
24	D2045	Cover pressure switch	1	
Not illus.	D2138	Timing label for C.B. cover	1	

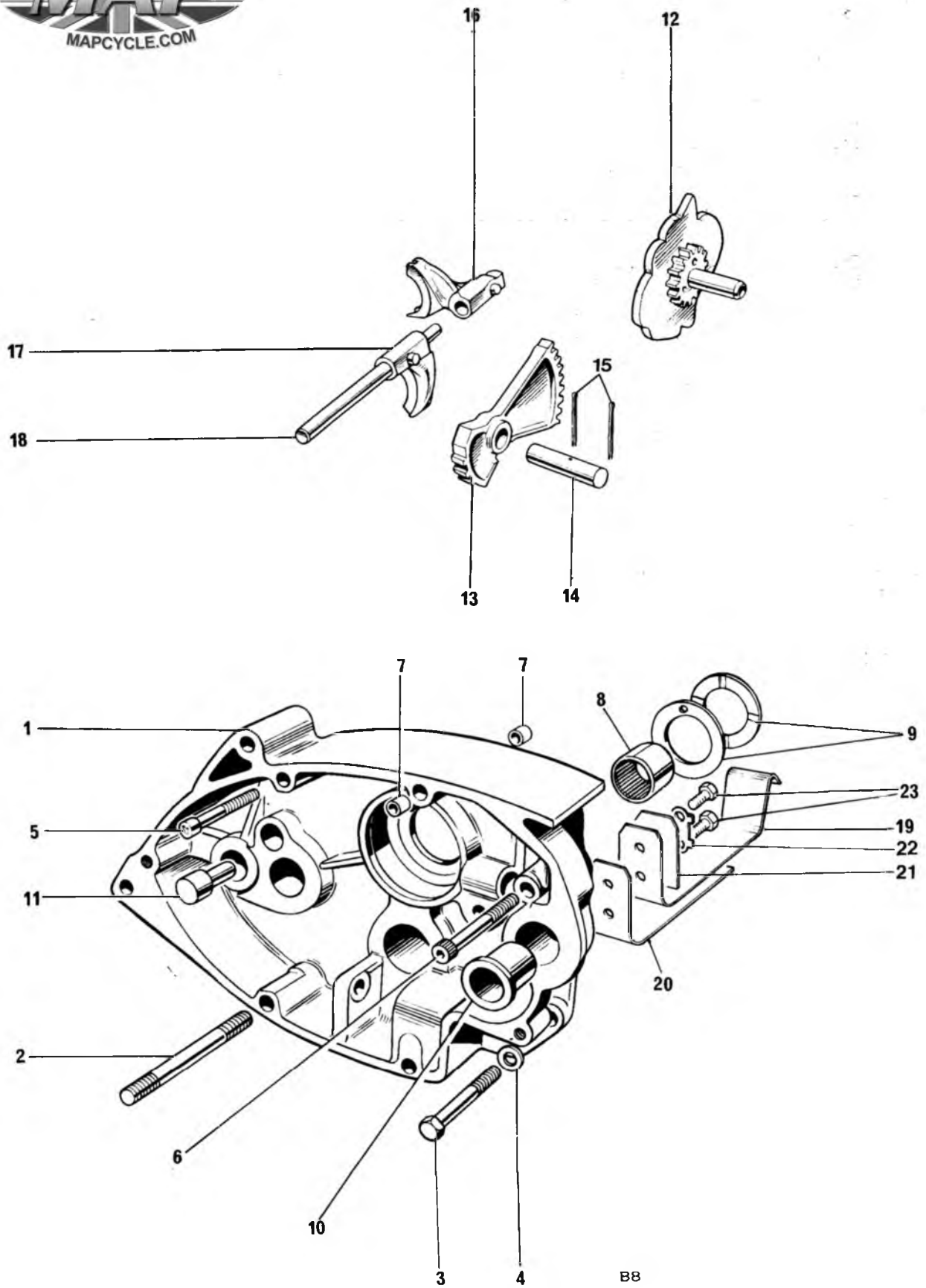

Fig. 9 GEARBOX INNER COVER AND SELECTORS

Ref. No.	Part No.	DESCRIPTION	QUANTITY	REMARKS
----------	----------	-------------	----------	---------

GEARBOX INNER COVER AND SELECTORS

1	T4293	Gearbox inner cover	1	
2	14-1427	Stud	2	
3	S1907	Bolt	1	
4	E3446	Washer	1	
5	14-6608	Screw	1	
6	14-7023	Screw	1	
7	T989	Hollow dowel	4	
8	T1614	Layshaft bearing	1	
9	T1607	Thrust washer	2	
10	T412	Gearchange spindle bush	1	
11	T45	Kickstarter stop	1	
12	T4055	Gear selector camplate	1	
13	T397	Camplate operating quadrant	1	
14	T1896	Quadrant spindle	1	
15	—	Split pin ($\frac{5}{64}$ in. x $1\frac{3}{8}$ in.)	1	Reference only
16	T4308	Mainshaft selector fork	1	
17	T4307	Layshaft selector fork	1	
18	T3989	Selector fork rod	1	
19	T4288	Leaf spring	1	
20	T4289	Leaf spring support	1	
21	T4290	Leaf spring top plate	1	
22	T4291	Tab washer	1	
23	F4771	Screw	2	

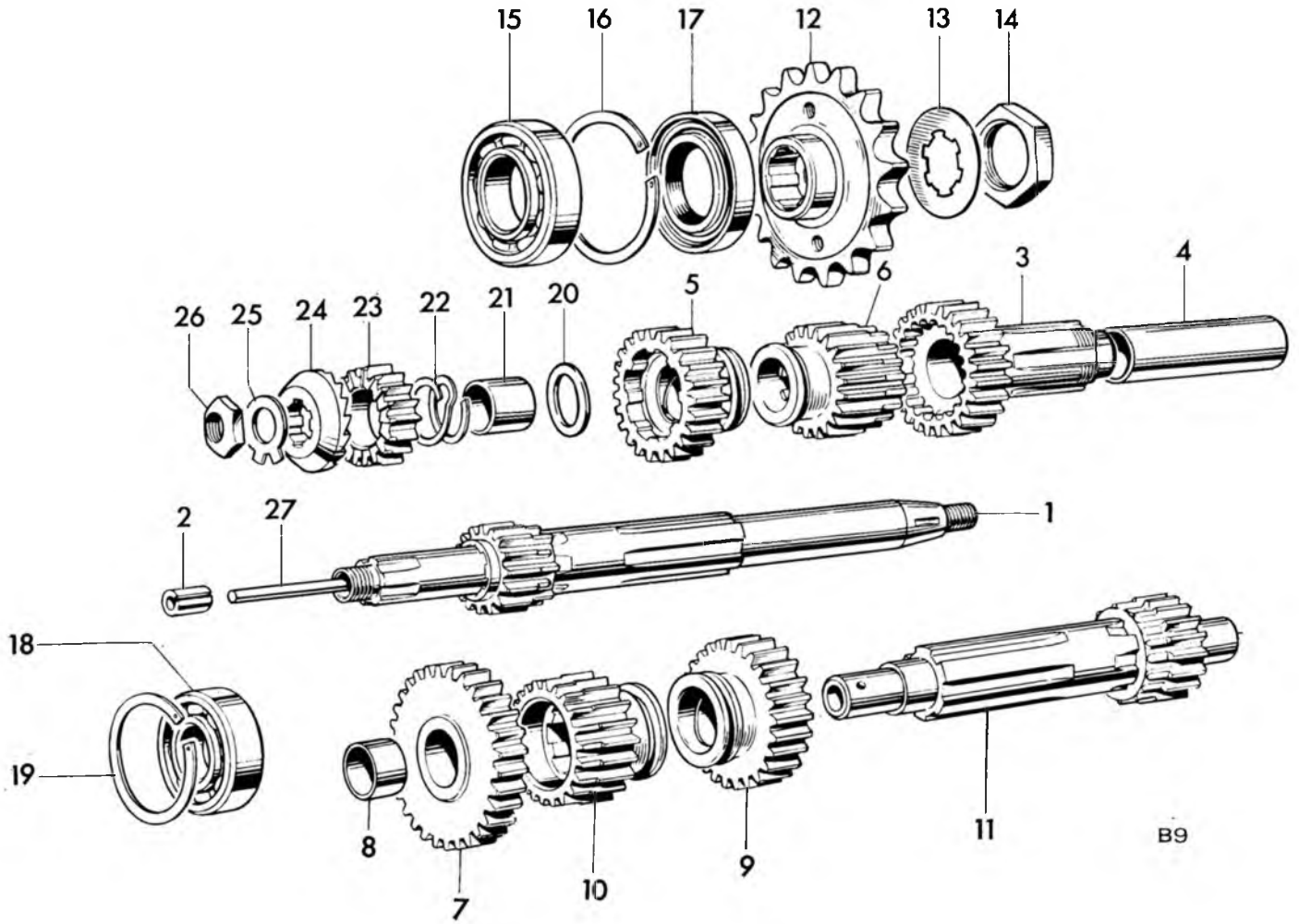

Fig. 10 GEARBOX SHAFTS AND GEARS

B9

GEARBOX SHAFTS AND GEARS

1	T4158	MAINSHAFT c/w LOW GEAR (16T)	1	
2	T3988	Clutch rod bush	1	
3	T4332	MAINSHAFT HIGH GEAR (26T)	1	
4	T4006	High gear bush	1	
5	T3889	Mainshaft third gear (23T)	1	
6	T4335	Mainshaft second gear (20T)	1	
7	T3862	LAYSHAFT LOW GEAR (30T)	1	
8	T928	Low gear bush	1	
9	T3861	Layshaft second gear (26T)	1	
10	T3890	Layshaft third gear (22T)	1	
11	T4345	Layshaft c/w high gear (20T)	1	
12	T1952	Gearbox sprocket (15 teeth)	1	
12	T1953	Gearbox sprocket (16 teeth)	1	
12	T1916	Gearbox sprocket (17 teeth)	1	
12	T1917	Gearbox sprocket (18 teeth)	1	
12	T1918	Gearbox sprocket (19 teeth)	1	
12	T1919	Gearbox sprocket (20 teeth)	1	
13	T2116	Tab washer	1	
14	T440	Gearbox sprocket nut	1	
15	D3556	High gear bearing	1	
16	T489	Circlip	1	
17	T946	Oil seal	1	
18	D3552	Mainshaft bearing	1	
19	T4113	Circlip	1	
20	T1962	Plain washer	1	
21	T1963	Pinion sleeve	1	
22	T1250	Pinion spring	1	
23	T730	Kickstarter pinion	1	
24	T731	Kickstarter ratchet	1	
25	T2240	Tab washer	1	
26	S594	Nut	1	
27	T1736	Clutch operating rod	1	

WIDE RATIO GEARS

3	T3657	MAINSHAFT HIGH GEAR (28T)	1	
6	T4161	Mainshaft second gear (19T)	1	
9	T4160	Layshaft second gear (27T)	1	
11	T4159	Layshaft c/w high gear (18T)	1	

CLOSE RATIO GEARS

1	T4173	MAINSHAFT c/w LOW GEAR (18T)	1	
3	T4172	MAINSHAFT HIGH GEAR (24T)	1	
5	T4169	Mainshaft third gear (23T)	1	
6	T4167	Mainshaft second gear (21T)	1	
7	T4163	LAYSHAFT LOW GEAR (28T)	1	
9	T4166	Layshaft second gear (25T)	1	
10	T4168	Layshaft third gear (23T)	1	
11	T4162	Layshaft c/w high gear (22T)	1	

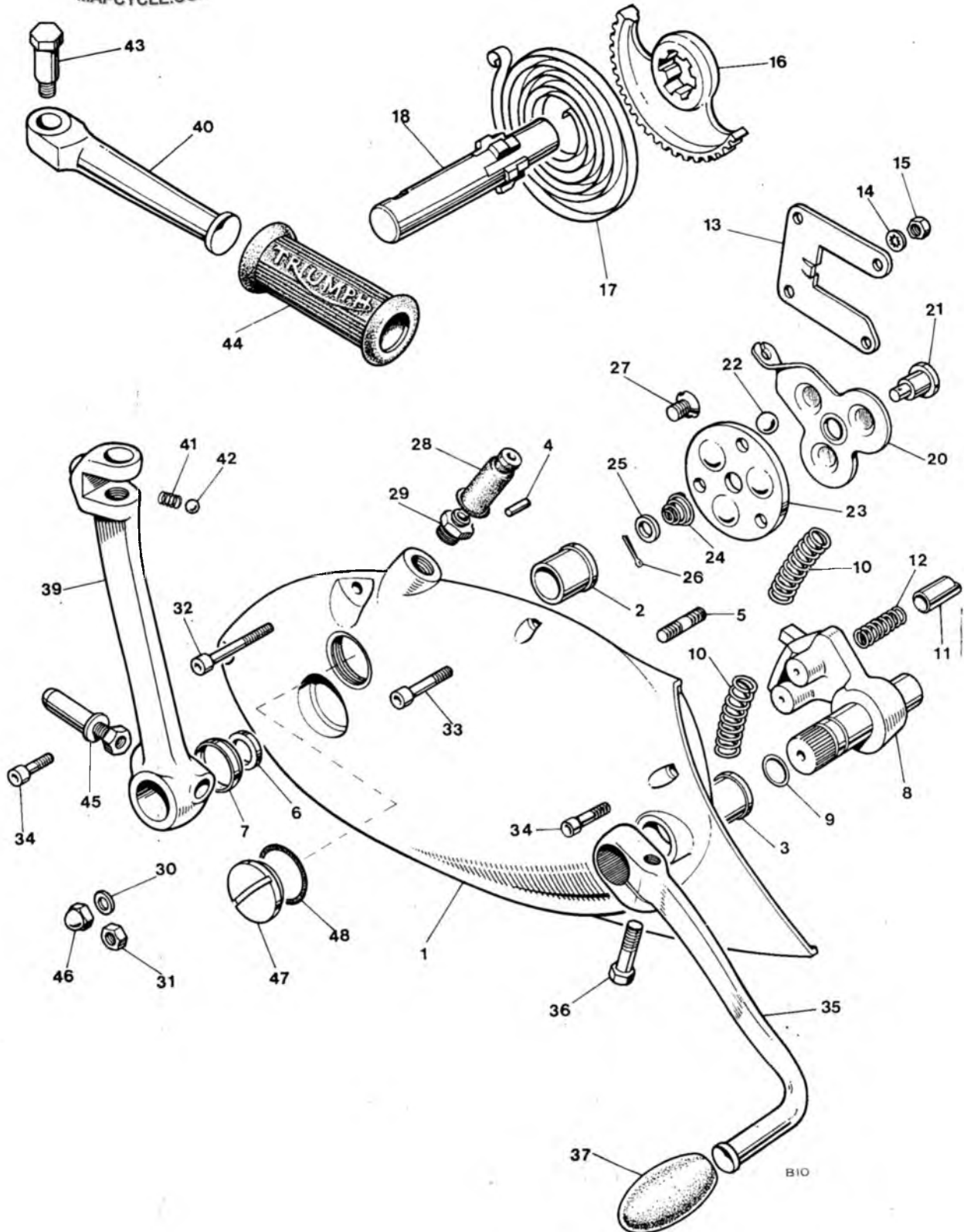

Fig 11. GEARBOX OUTER COVER

GEARBOX OUTER COVER

1	T3760	GEARBOX OUTER COVER	1	
2	T23	Kickstarter spindle bush	1	
3	T57	Gearchange spindle bush	1	
4	T47	Kickstarter spring anchor pin	1	
5	S547	Guide plate stud	4	
6	T1956	Oil seal	1	
7	T1955	Oil seal housing	1	
8	T408/9	Gearchange quadrant	1	57-0408/1009
9	E330960-3530	Rubber "O" ring	1	
10	T404	Quadrant return spring	2	
11	T406	Gearchange quadrant plunger	2	
12	T405	Plunger spring	2	
13	T407	Guide plate	1	
14	E1612	Serrated washer	4	
15	14-0301	Nut	4	
16	T4117	Kickstarter quadrant	1	
17	T31	Kickstarter return spring	1	
18	T24A 57-4756	Kickstarter axle	1	
19	T3629 57-4587	CLUTCH LEVER ASSEMBLY	1	
20	T2191 57-4441	Clutch lever	1	
21	T1710	Lever shaft	1	
22	D2368	Ball, $\frac{3}{8}$ in. diam.	3	
23	T3761	Thrust plate	1	
24	T1712	Return spring	1	
25	GS127 57-3673	Plain washer	1	
26	— 60-2701	Split pin ($\frac{5}{16}$ in. x $\frac{1}{2}$ in.)	1	Reference only
27	S1879	Countersunk screw	2	
28	T1646	Rubber cover	1	
29	T3762	Abutment for clutch cable	1	
30	S25-360-4247	Plain washer	2	
31	14-0302	Nut	1	
32	S1878	Screw	2	
33	14-6609	Screw	2	
34	14-6608	Screw	1	
35	T3757 57-7010	Gearchange pedal	1	
36	14-0201	Bolt	1	
37	T2450	Pedal rubber	1	
38	T3632 57-7018	FOLDING KICKSTARTER	1	
39	T2173 57-2173	Kickstarter lever	1	
40	T1272 57-7017	Kickstarter pedal	1	
41	T1167	Pedal locating spring	1	
42	S70-3 60-2364	Steel ball, $\frac{1}{4}$ in. diam.	1	
43	S541	Pedal bolt	1	
44	T2330	Pedal rubber	1	
45	T4356	Cotter pin c/w nut and washer	1	
46	S544	Domed nut	1	
47	T2166	Filler plug	1	
48	E8782	"O" ring	1	

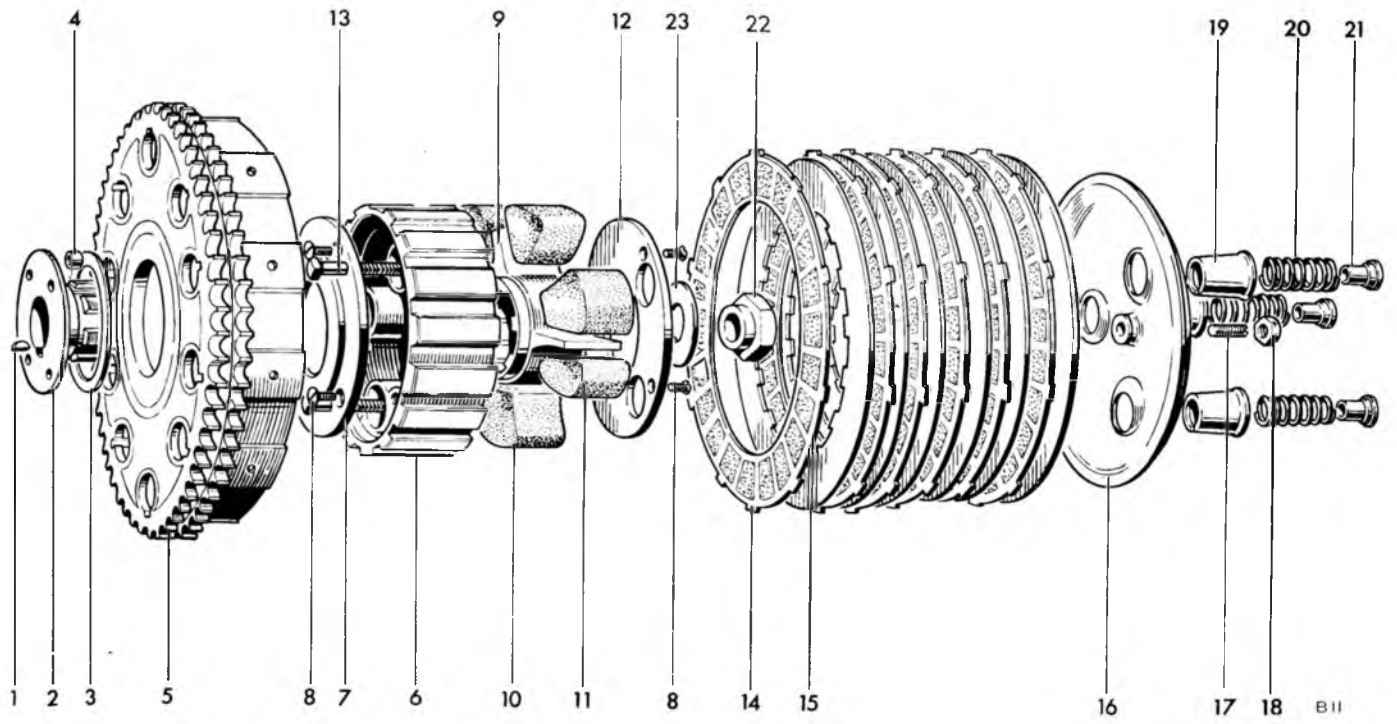

Fig. 12. CLUTCH

Ref. No.	Part No.	DESCRIPTION	QUANTITY	REMARKS
----------	----------	-------------	----------	---------

CLUTCH

1	S586	Clutch securing nut	1	
2	T3929	Hub	1	
3	T3931	Thrust washer	1	
4	T394	Roller	20	
5	T1570	Sprocket and housing (58 teeth Duplex)	1	
6	T1719	Centre	1	
7	T1720	Inner plate	1	
8	T1040	Countersunk screw	6	
9	T2538	Shock absorber spider	1	
10	T1722	Drive rubber (large)	3	
11	T1723	Rebound rubber (small)	3	
12	T1724	Outer plate	1	
13	T423A <i>57-4754</i>	Screwed pin	3	
14	T1362 <i>57-4653</i>	Driving plate (bonded)	6	
15	T1363	Driven plate	6	
16	T2156	Pressure plate	1	
17	T2159	Adjuster pin	1	
18	14-0403	Nut	1	
19	T1931	Spring cup	3	
20	T1830	Spring	3	
21	T2526	Pressure nut	3	
22	S66-1 <i>60-4253</i>	Key	1	
23	T2279	Cupped washer	1	

LATER MODELS USE THE FOLLOWING:—

6	T4438	Centre (shock absorber body)	1	
7	T4436	Inner plate	1	
8	S644	Bolt	3	
12	T4437	Outer plate	1	



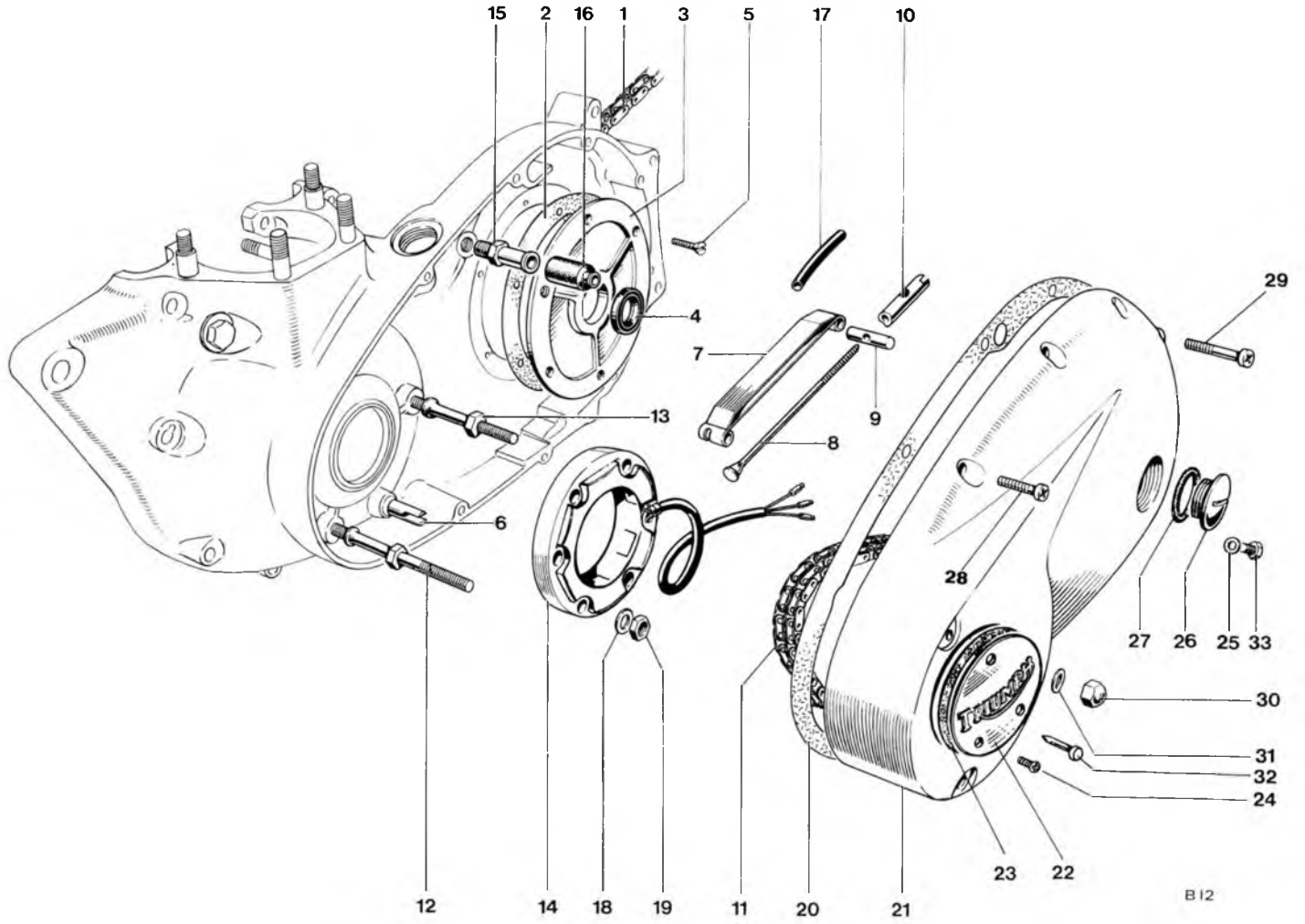

Fig. 13. CHAINCASE AND CHAINS

B 12

CHAINCASE AND CHAINS

1	D1915 <i>110056/106</i>	Rear chain, $\frac{3}{8}$ in. x $\frac{3}{8}$ in. x 106 links ...	1	
2	E11419	Joint washer ...	1	
3	E7037	Cover plate ...	1	
4	E7565	Oil seal ...	1	
5	E3821	Countersunk screw ...	6	
6	E5976 <i>70-5087</i>	Chain tensioner abutment ...	1	(also listed with crankcase group)
7	E6061	Chain tensioner blade ...	1	
8	E4152	Tie rod ...	1	
9	E5977	Trunnion ...	1	
10	E9703	Adjuster sleeve nut ...	1	
11	D477	Primary chain, $\frac{3}{8}$ in. Duplex x 84 links ...	1	
12	S1866	Stator stud ...	2	
13	S1867	Stator stud ...	1	
14	47205	Stator, RM21 (99-1006) ...	1	
15	E9360	Sleeve nut ...	1	
16	E4144	Rubber grommet ...	1	
17	E5449	Plastic sleeve ...	1	
18	S25-3 <i>60-4247</i>	Plain washer ...	3	
19	14-0702	Self-locking nut ...	3	
20	E11463	Joint washer ...	1	
21	E9245 <i>71-4072</i>	Chaincase ...	1	
22	T2440	Rotor cover ...	1	
23	E11457	Joint washer ...	1	
24	F4129	Screw ...	3	
25	E2441	Copper washer ...	1	
26	T2166	Filler plug ...	1	
27	E8782	"O" ring ...	1	
28	14-6608	Screw ...	6	
29	14-6620	Screw ...	2	
30	S544	Domed nut ...	2	
31	F1880	Copper washer ...	2	
32	T2443	Timing pointer ...	1	
33	14-6101	Level plug ...	1	

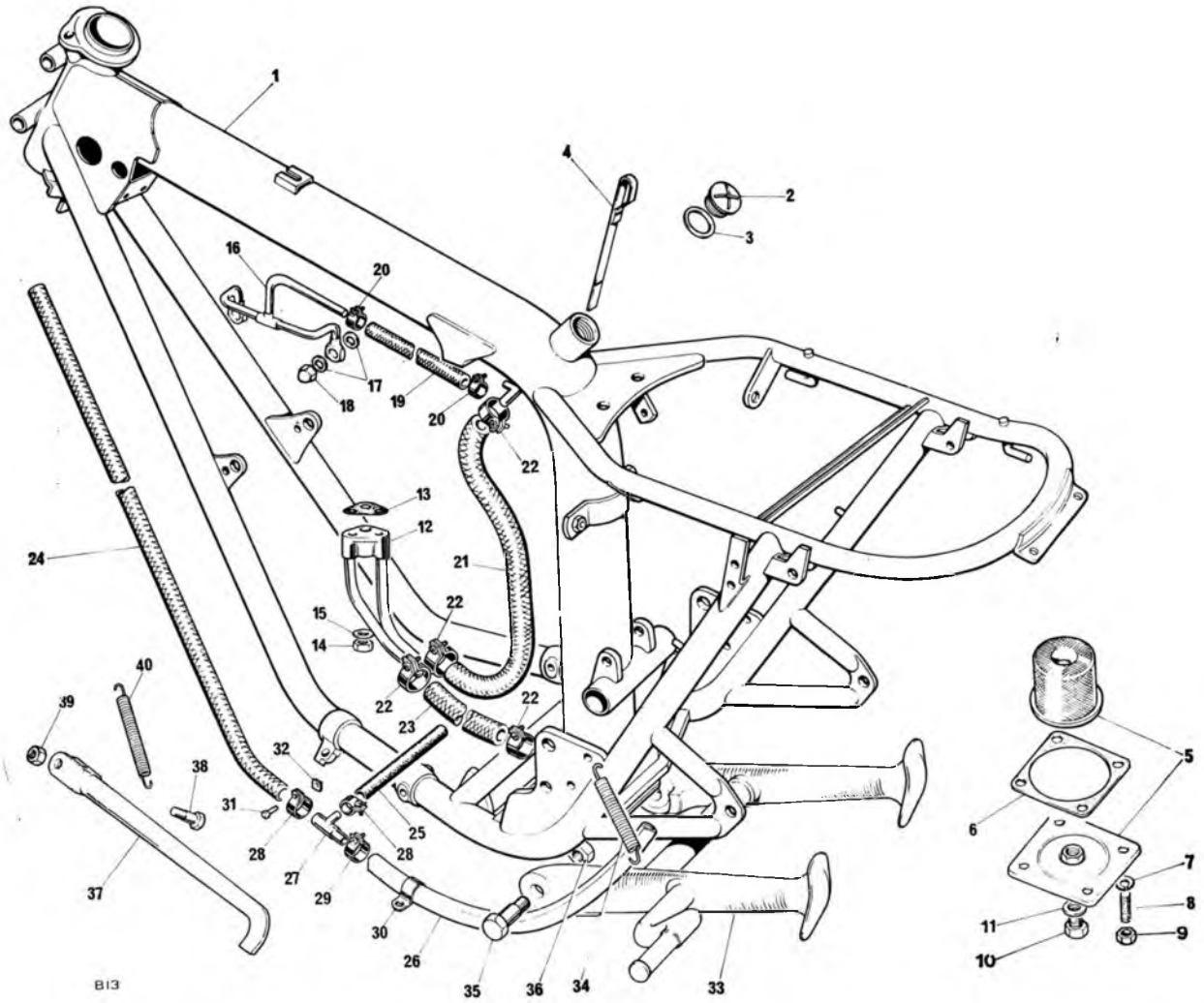

Fig. 14. FRAME

FRAME

1	F12089 83-4283	Frame	1	
2	E12744 71-2744	Oil filler cap	1	
3	D3616	"O" ring	1	
4	F13142	Dipstick	1	
5	F12826	*Oil filter and sump plate	1	
6	F12829	*Gasket	1	
7	D2330	Washer }	4	Sump plate to frame
8	S2109	Stud }	4	
9	14-1302	Nut }	4	
10	S1945	*Drain plug	1	
11	E12505	Joint washer	1	
12	E6930 71-7176	Oil junction block	1	
13	E11458	Joint washer	1	
14	S1908	Nut }	1	Junction block to crankcase
15	E3446	Washer }		
16	E12428	Rocker oil pipe	1	
17	E1335	Washer	4	
18	E1435	Nut	4	
19	E12337	Rocker feed pipe	1	
20	E8111 60-3524	Clip—rocker feed pipe	2	
21	E12345	Oil return pipe	1	
22	E6848	Clip—feed and return pipes	4	
23	E12347	Oil feed pipe	1	
24	E12349	Oil vent pipe	1	
25	E11149	Crankcase breather pipe—front	1	
26	F11614	Crankcase breather pipe—rear	1	
27	F11610	"T" piece	1	
28	D2253	Clip—breather pipe—front	2	
29	D2252	Clip—breather pipe—rear	1	
30	F11615	Clip—breather pipe to fender	4	
31	H3894	Screw	4	
32	F4717	Nut	4	
33	F1262 83-4941	Centre stand	1	
34	F13793	Spring	1	
35	S2077	Pivot bolt	2	
36	14-1304	Nut	2	
37	F11560	Prop stand	1	
38	F7021	Bolt	1	
39	14-1303	Nut	1	
40	F8382	Spring	1	
Not illus.	D3361 99-3509	Transfer "Made in England"	1	
Not illus.	D2452 N.L.A.	Transfer—Safety Standards	1	
Not illus.	14-0114	Bolt }	1	Prop stand stop
Not illus.	14-0402	Nut }		

* LATER MODELS USE THE FOLLOWING:—

F13642	Oil filter assembly	1
F12829	Gasket	2
14-0113	Drain plug	1
F13643 83-3815	Sump plate	1

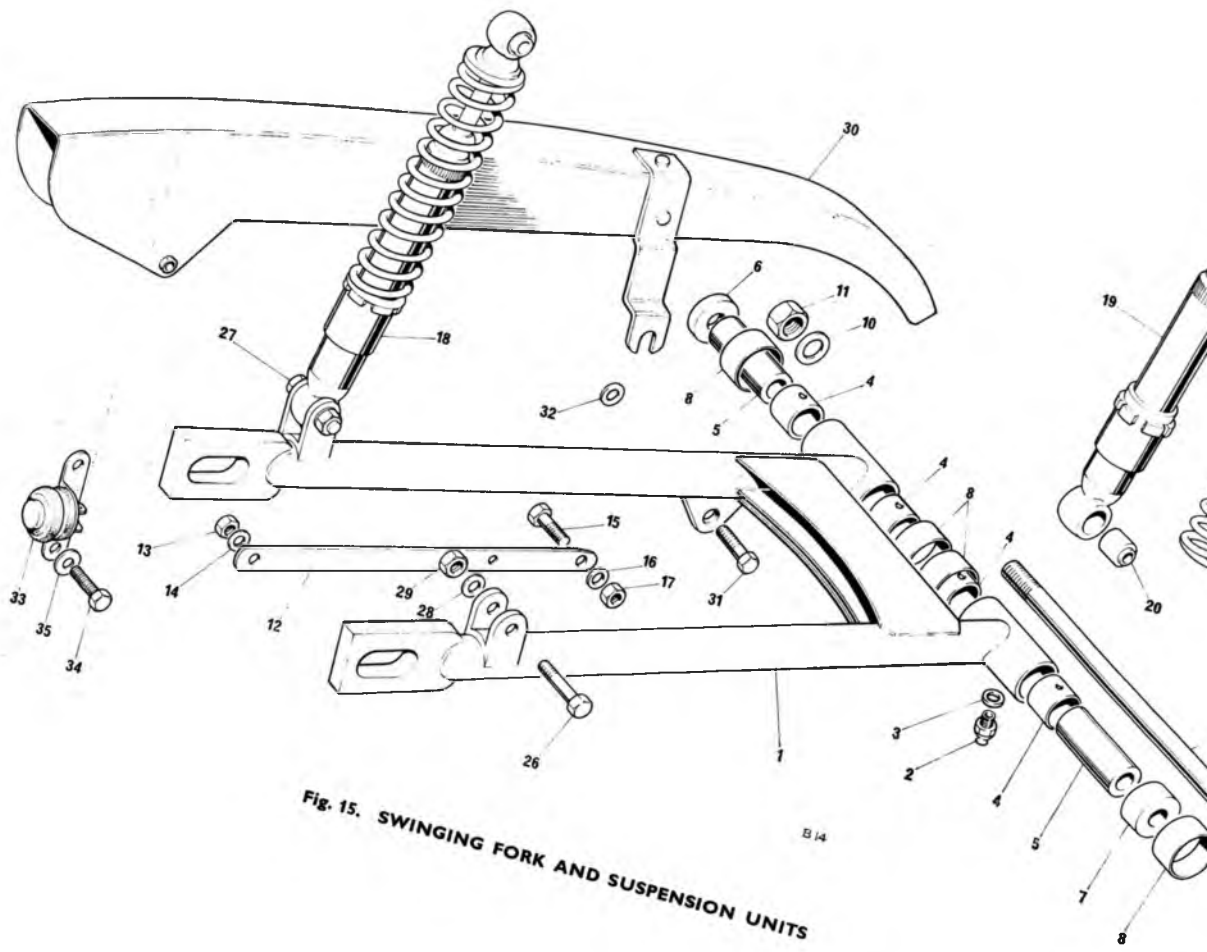

FIG. 15. SWINGING FORK AND SUSPENSION UNITS

B 14

Ref. No.	Part No.	DESCRIPTION	QUANTITY	REMARKS
----------	----------	-------------	----------	---------

SWINGING ARM AND SUSPENSION UNITS

1	F12513	SWINGING ARM	1	
2	D1841	Grease nipple	2	
3	WE170	Washer, grease nipple	2	
4	F12521	Bush, pivot arm	4	
5	F12691	Sleeve, swinging arm pivot	2	
6	F12690	Distance piece R.H.	1	
7	F12689	Distance piece L.H.	1	
8	F12692	Dirt excluder	4	
9	S2087	Stud, swinging arm pivot	1	
10	F12266	Washer, swinging arm pivot	2	
11	14-1307	Nut, swinging arm pivot	1	
12	F12656	Brake torque stay	1	
13	14-1304	Nut, torque stay to brake plate	1	
14	D2350	Washer, torque stay to brake plate	1	
15	14-0133	Bolt, torque stay to swinging arm	1	
16	W2330	Washer, torque stay to swinging arm	1	
17	14-1304	Nut, torque stay to swinging arm	1	
18	64052341	SUSPENSION UNIT (D2294)	2	
19	64052090	Damper unit	Reference only	
20	64533645	Bonded bush (99-0122)	4	
21	9054/171	Spring retainer (99-0107)	4	
22	64544754	Spring, 110 lbs. chrome (99-1139)	2	
23	14-0235	Bolt, damper—top	2	
23	S1997	Stud, damper—top L.H.	1	
24	D2332	Washer, damper—top	2	
25	14-1303	Nut, damper—top	2	
26	14-0234	Bolt, damper, lower—L.H.	1	
27	14-2034	Bolt, damper, lower—R.H.	1	
28	D2321	Washer damper lower	2	
29	14-1303	Nut damper lower	2	
30	F12641	Chainguard	1	
31	14-0206	Bolt, chainguard fixing—front	1	
32	D2347	Washer, chainguard fixing—front	1	
33	34815	Stop lamp switch—118SA (99-1028)	1	
34	D3550	Screw	2	
35	H1388	Washer	2	

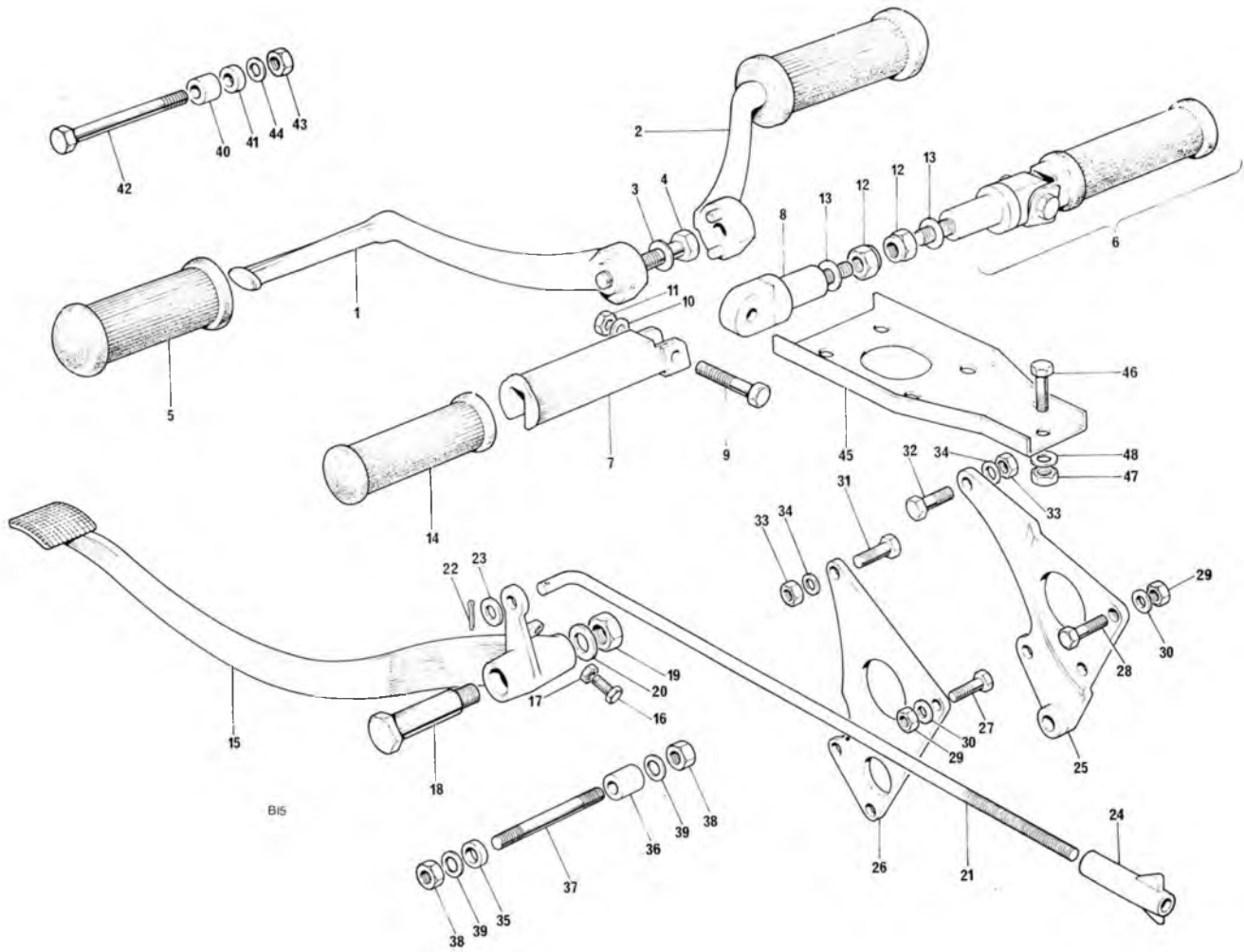

Fig. 16. MOTOR UNIT FITTING AND FOOTRESTS

Ref. No.	Part No.	DESCRIPTION	QUANTITY	REMARKS
MOTOR UNIT FITTINGS AND FOOTRESTS				
1	F12855	Footrest—L.H.	1	
2	F12854	Footrest—R.H.	1	
3	14-0259	Bolt	2	
4	D2333	Washer	2	
5	F9279	Footrest rubber	2	
6	F12841	PILLION FOOTREST	2	
7	F9053	Pedal	1	
8	F13207	Hanger bolt	1	
9	14-0217	Bolt	1	
10	F9089	Washer	1	
11	14-1302	Nut	1	
12	14-1303	Nut	1	
13	F2184	Washer	1	
14	F9054	Footrest rubber	1	
15	F12666	Rear brake pedal	1	
16	14-0103	Screw	1	
17	14-0301	Nut	1	
18	S2045	Pivot pin	1	
19	14-1303	Nut	1	
20	E8084	Washer	1	
21	F12860	Rear brake operating rod	1	
22	—	Split pin ($\frac{1}{16}$ in. x $\frac{3}{8}$ in.)	1	Reference only
23	D2393	Washer	1	
24	F7387	Adjuster nut—brake rod	2	
25	F13024	Rear motor plate R.H.	1	
26	F13023	Rear motor plate—L.H.	1	
27	14-0115	Bolt	5	
28	14-0116	Bolt	1	
29	14-1302	Nut	6	
30	D2330	Washer	6	
31	14-0220	Bolt	2	
32	14-0221	Bolt	2	
33	14-1302	Nut	4	
34	D2321	Washer	4	
35	F12846	Distance piece—L.H.	1	
36	F12847	Distance piece—R.H.	1	
37	S2112	Stud	1	
38	14-0304	Nut	2	
39	D2332	Washer	2	
40	F12848	Distance piece—L.H.	1	
41	F12849	Distance piece—R.H.	1	
42	14-0254	Bolt	1	
43	14-1304	Nut	1	
44	D2332	Washer	1	
45	F13537	Steady bracket motor to frame	1	
46	14-0126	Bolt	1	
47	14-1303	Nut	1	
48	D2321	Washer	1	

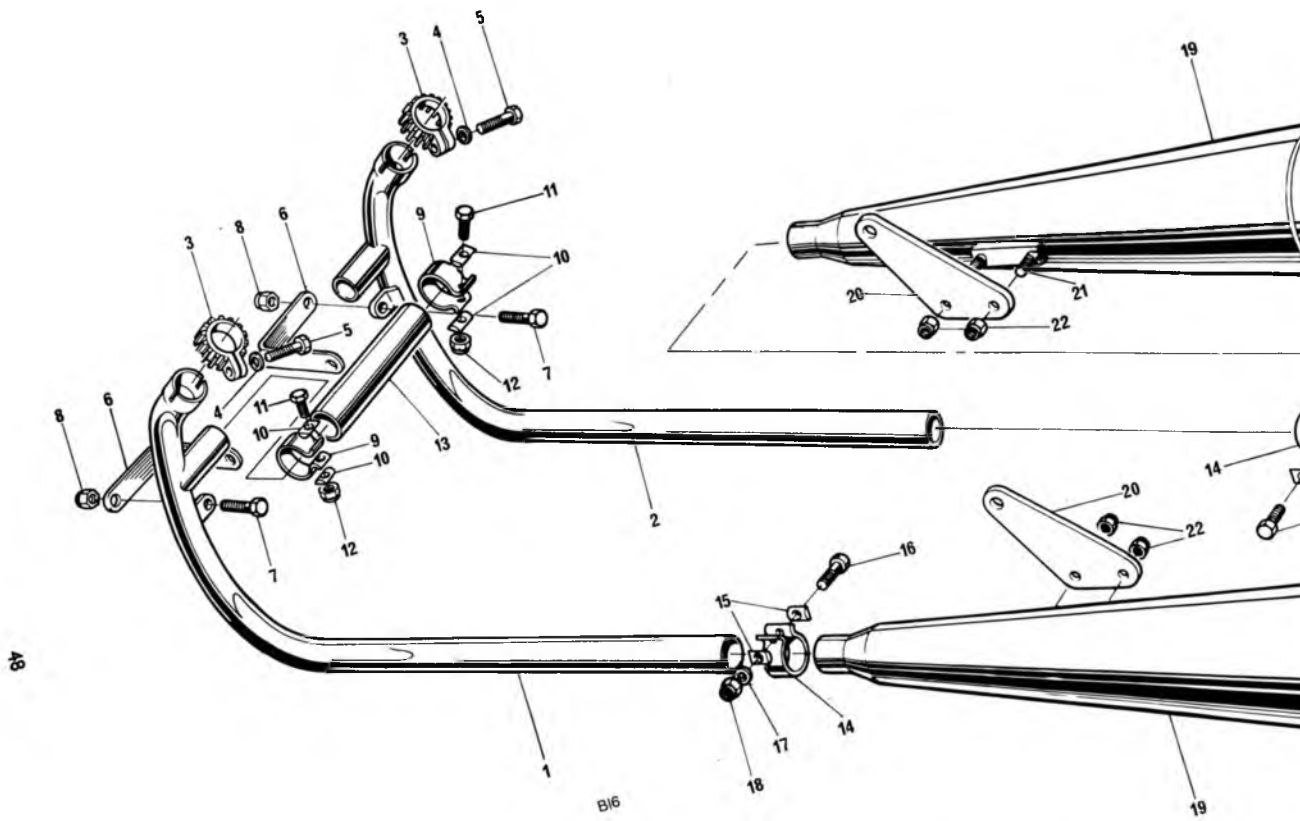

Fig. 17. EXHAUST PIPES AND MUFFLERS

Ref. No.	Part No.	DESCRIPTION	QUANTITY	REMARKS
----------	----------	-------------	----------	---------

EXHAUST PIPES AND MUFFLERS, TR6R, T120R

1	E12753	Exhaust pipe—L.H.	1	
2	E12756	Exhaust pipe—R.H.	1	
3	E10216	Finned clip	2	
4	E8860	Spherical washer	2	
5	E6744	Bolt	2	
6	E6857	Exhaust pipe stay	2	
7	E6179	Screw	2	
8	E7471	Nut	2	
9	E7512	Clip	2	
10	E3768	“D” washer	4	
11	14-0217	Bolt	2	
12	14-1202	Nut	2	
13	E9888	Coupling pipe	1	
14	E2271	Clip	2	
15	E3768	“D” washer	4	
16	14-0219	Bolt	2	
17	S25-3	Washer	2	
18	14-1302	Nut	2	
19	E12382	Muffler	2	
20	E12282	Hanger—muffler and pillion footrest	2	
21	14-0101	Bolt	4	
22	14-1301	Nut	4	

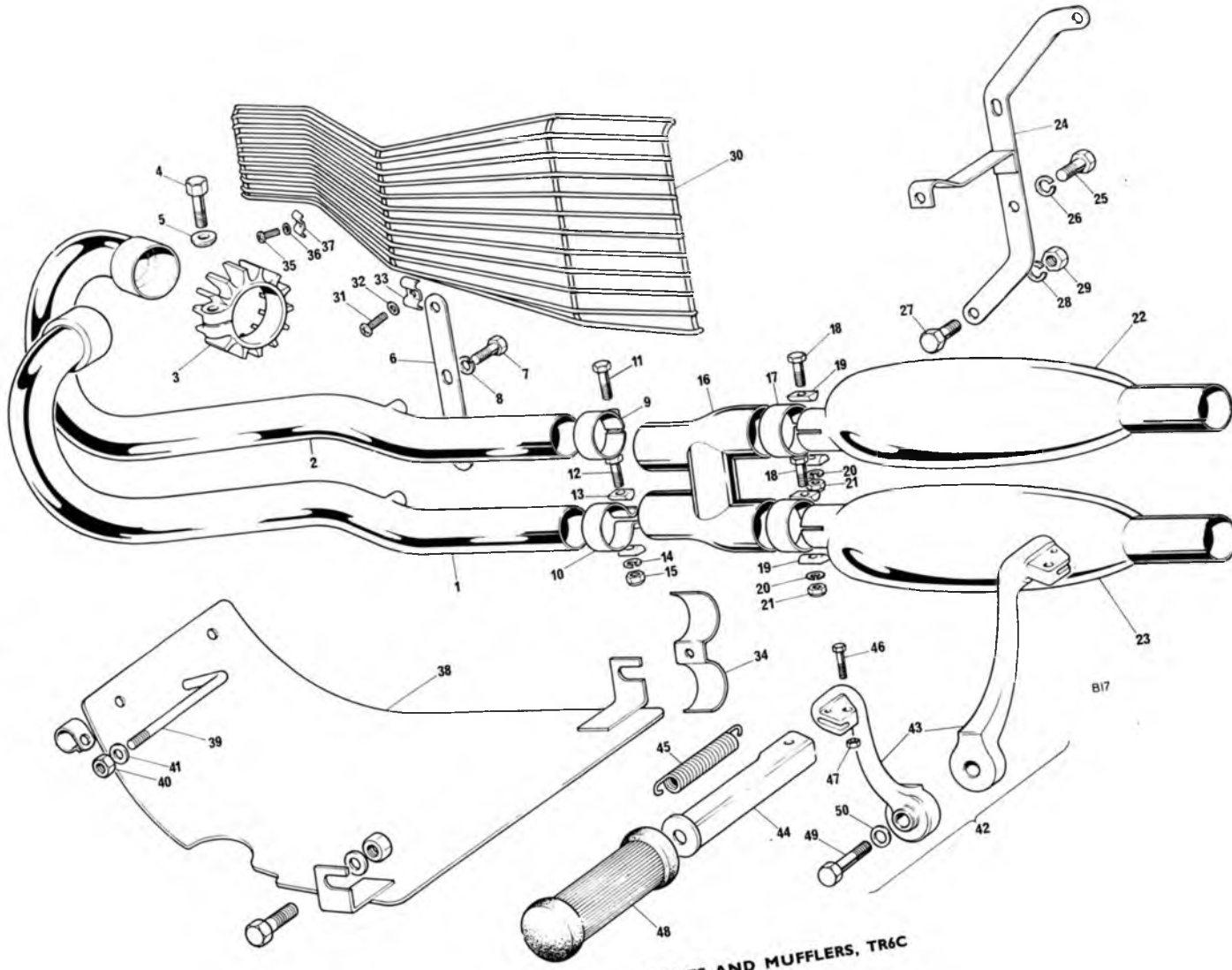
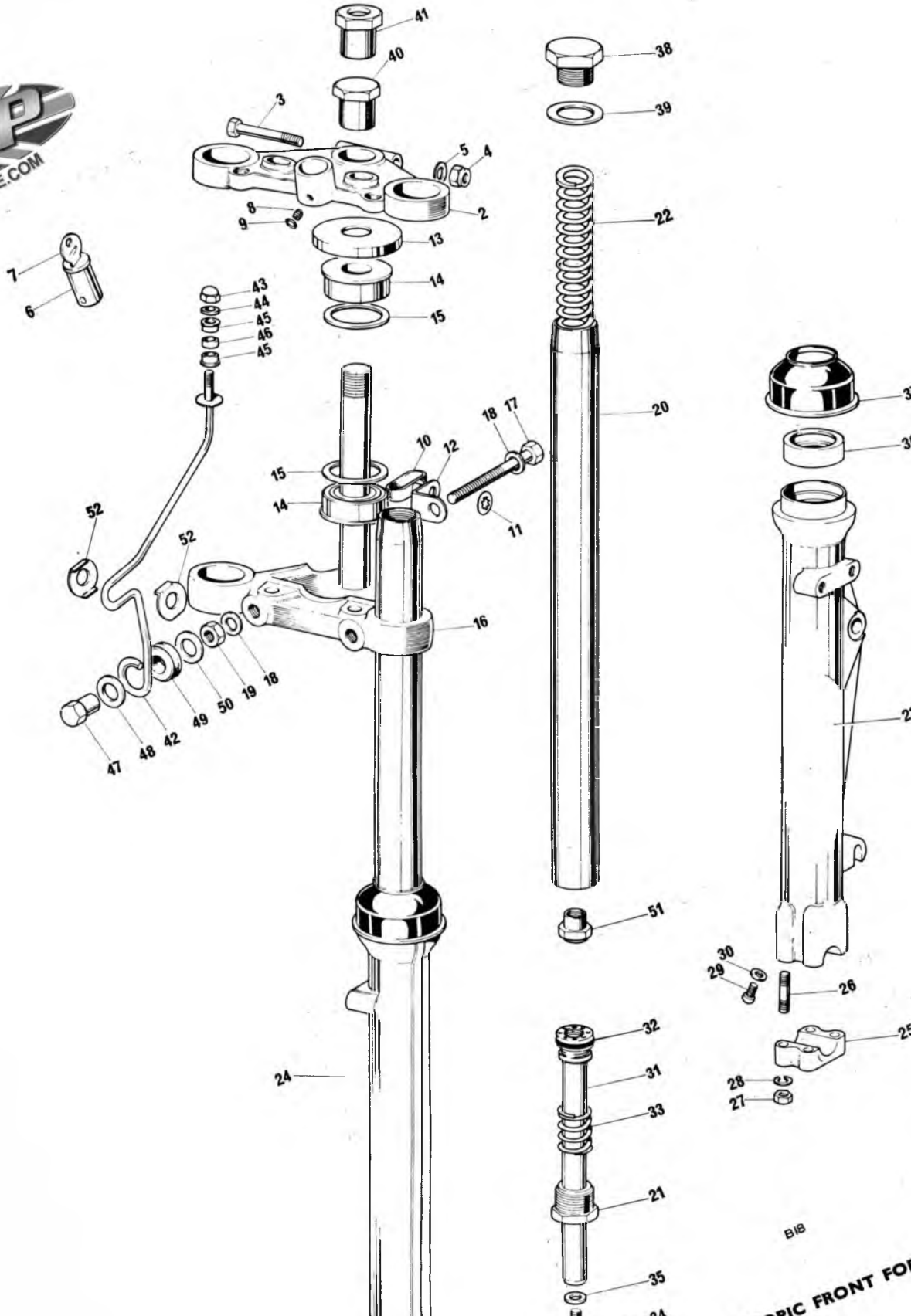

Fig. 18. EXHAUST PIPES AND MUFFLERS, TR6C

B17

Ref. No.	Part No.	DESCRIPTION	QUANTITY	REMARKS
EXHAUST PIPES, MUFFLERS AND FOLDING FOOTRESTS, TR6C				
1	E11900	Exhaust pipe—lower	1	
2	E11901	Exhaust pipe—upper	1	
3	E10216	Finned clip	2	
4	E6744	Bolt	2	
5	E8860	Spherical washer	2	
6	E6978	Exhaust pipe stay	1	
7	14-0113	Bolt	3	
8	S26-3	Spring washer	3	
9	E7299	Clip—upper	1	
10	E5874	Clip—lower	1	
11	14-0116	Bolt	1	
12	14-0219	Bolt	1	
13	E3768	“D” washer	2	
14	S26-3	Spring washer	1	
15	14-1202	Nut	1	
16	E9673	Connector	1	
17	E2271	Clip	2	
18	14-0219	Bolt	2	
19	E3768	“D” washer	4	
20	S26-3	Spring washer	2	
21	14-1302	Nut	2	
22	E12019	Muffler—upper	1	
23	E12020	Muffler—lower	1	
24	E12511	Muffler—hanger	1	
25	S1822	Bolt	2	
26	S26-3	Spring washer	2	
27	14-0115	Bolt	1	
28	S26-3	Spring washer	1	
29	S1933	Spacer nut	1	
30	E9680	Leg guard	1	
31	S1953	Screw	1	
32	E9857	Washer	1	
33	E9688	Clip	1	
34	E9696	Bracket	1	
35	S1954	Screw	1	
36	E9857	Washer	1	
37	E9688	Clip	1	
38	E12851	Crankcase undershield	1	
39	S2096	Hooked stud	2	
40	14-1301	Nut	2	
41	D2320	Washer	2	
42	F13139	FOLDING FOOTREST—R.H.	1	
42	F12856	FOLDING FOOTREST—L.H.	1	
43	F13140	Footrest hanger—R.H.	1	
43	F12858	Footrest hanger—L.H.	1	
44	F13092	Footrest pedal	1	
45	F13095	Spring	1	
46	14-0216	Bolt	1	
47	14-1302	Nut	1	
48	F9051	Footrest rubber	1	
49	S1969	Bolt	2	
50	F8243	Washer	2	



B18

FRONT FORK

Ref. No.	Part No.	DESCRIPTION	QUANTITY	REMARKS
----------	----------	-------------	----------	---------

TELESCOPIC FRONT FORK

1	H4080	FORK ASSEMBLY	1	
1	H4081	FORK ASSEMBLY	1	TR6C
2	H4035	Top Yoke	1	
3	14-0234	Pinch Bolt	1	
4	14-1303	Nut	1	
5	E8084	Washer	1	
6	F6738	Lock c/w 2 keys	1	
7	D623	Key (state serial No.)	1	
8	S578	Grub screw	1	
9	H2266	Sealing washer	1	
10	H2270	Brake cable retainer	1	
11	F8245	Starlock washer	1	
12	H3682	Retaining bracket	1	
13	F12007	Abutment ring	2	
14	H4031	Taper roller bearing	2	
15	H4028	Dust cover	2	
16	H4082	Bottom yoke and stem	1	
17	14-023R	Pinch bolt	2	
18	E8084	Washer	4	
19	14-1303	Nut	2	
20	H4007	Stanchion	2	
21	H4076	End plug	2	
22	H4087	Main spring	2	
23	H3954	Outer member—R.H.	1	
24	H3952	Outer member—L.H.	1	
25	H3947	Cap wheel spindle	2	
26	S2102	Stud	8	
27	14-0302	Nut	8	
28	D2428	Washer	8	
29	H3894	Drain plug	2	
30	H3893	Washer	2	
31	H4200	Damper tube and valve assembly	2	
32	H4003	"O" ring—damper valve	2	
33	H4009	Recoil spring	2	
34	14-1019	Cap screw-damper tube	2	
35	H4004	Cap screw seal	2	
36	H4001	Oil seal outer member	2	
37	H4002	Scraper sleeve outer member	2	
38	H4258	Top cap nut	2	
39	H4166	Washer	2	
40	H4029	Steering stem nut (without steering damper)	1	
41	H4092	Steering stem nut (with steering damper)	1	
42	H4058	Headlamp bracket—L.H.	1	
42	H4060	Headlamp bracket—R.H.	1	
42	H4088	Headlamp bracket—L.H.	1	
42	H4090	Headlamp bracket—R.H.	1	
43	S1809	Nut	2	
44	D2338	Washer	2	
45	F12209	Bush	4	
46	F12211	Spacer	2	

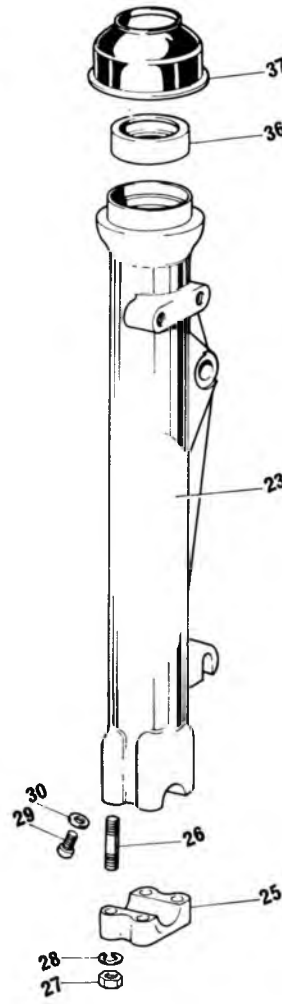
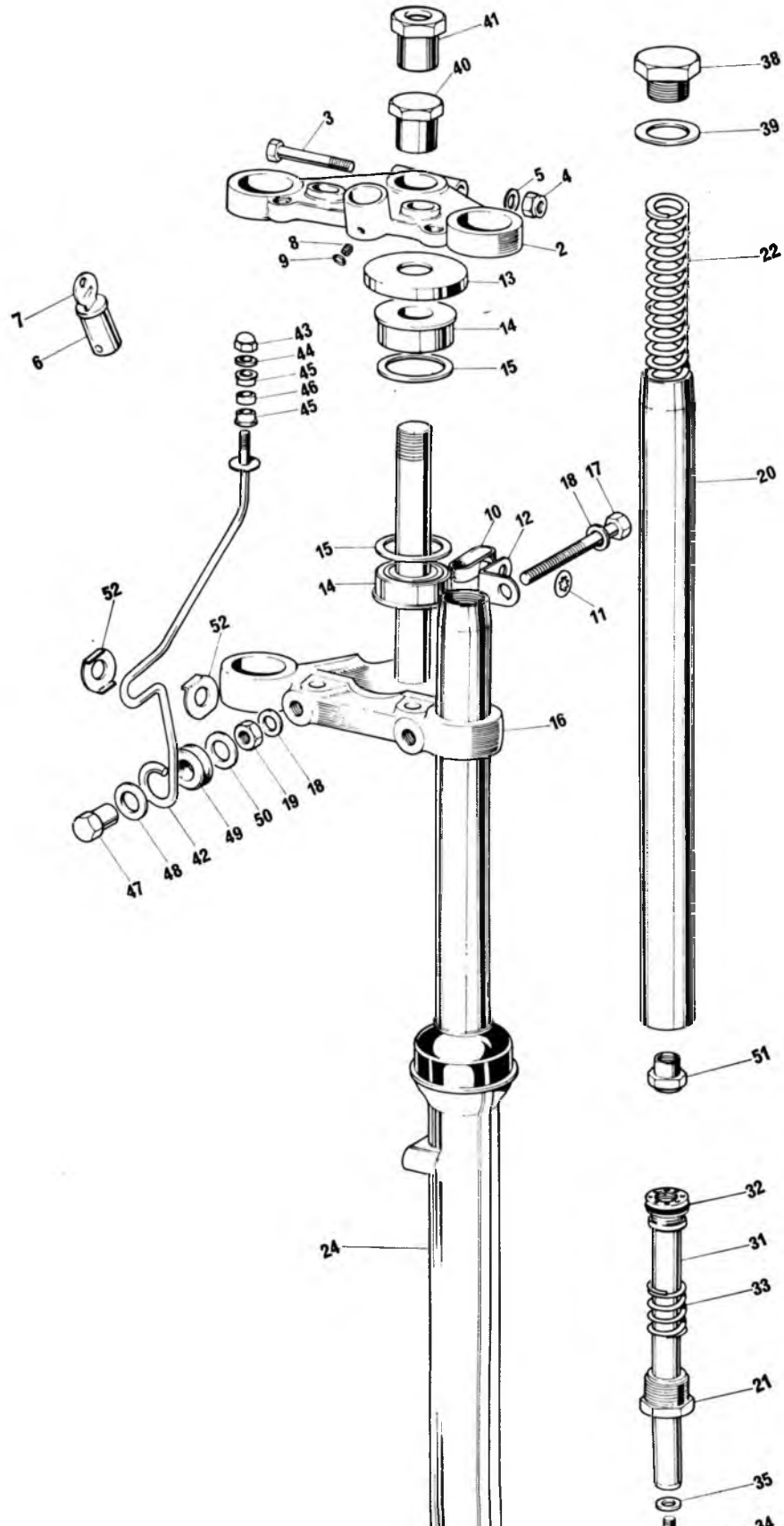

B18

OPIC FRONT FOR

Ref. No.	Part No.	DESCRIPTION	QUANTITY	REMARKS
TELESCOPIC FRONT FORK				
47	S2062	Sleeve nut	2	
48	D2333	Washer	2	
49	D2630	Grommet	2	
50	F9046	Washer	2	
51	H4012	Nut—damper valve	2	
52	F12216	Clamp washer	4	

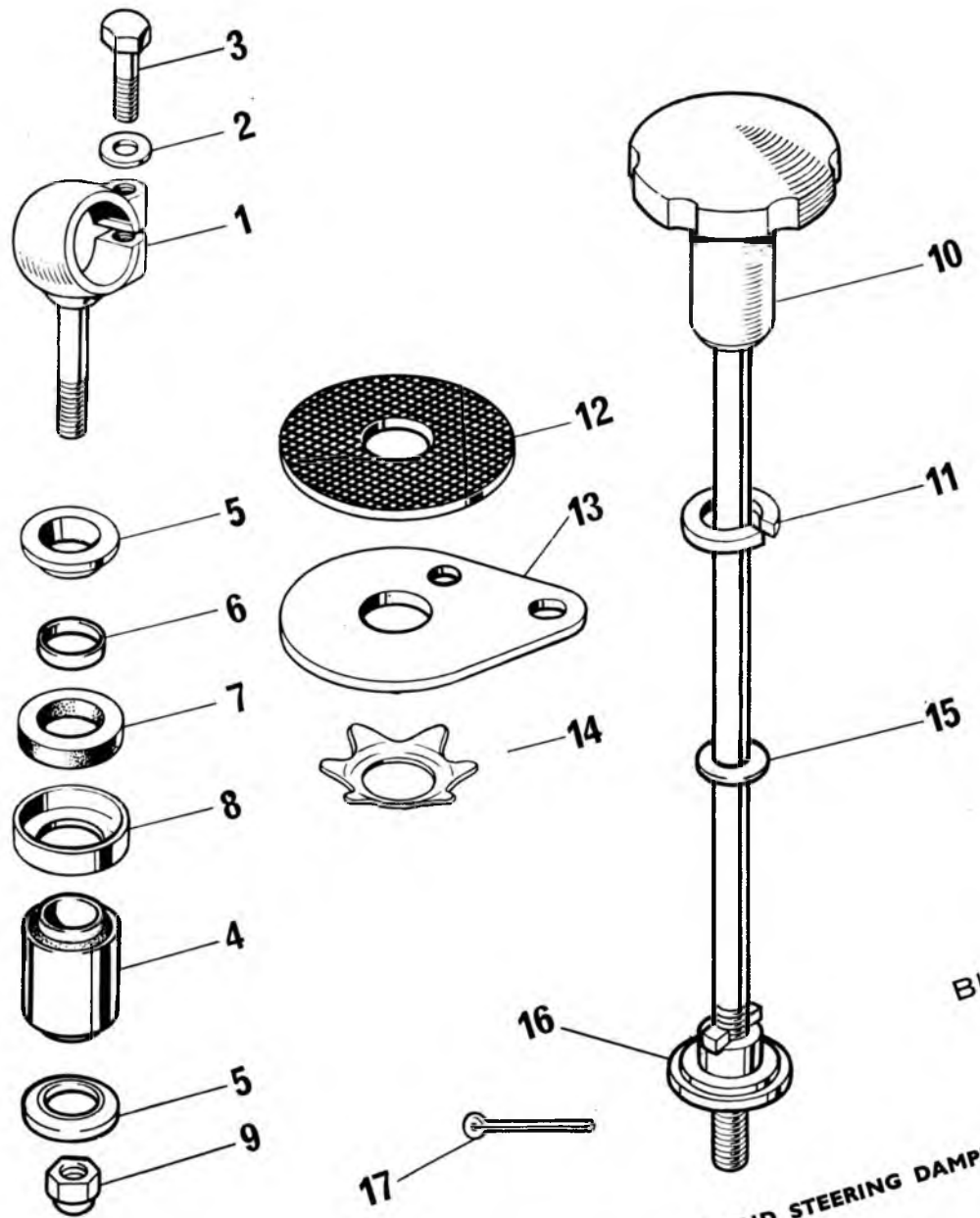

Fig. 20. HANDLEBAR MOUNTINGS AND STEERING DAMPER

B19

Ref. No.	Part No.	DESCRIPTION	QUANTITY	REMARKS
----------	----------	-------------	----------	---------

HANDLEBAR MOUNTINGS AND STEERING DAMPER

1	H2291	Handlebar eyebolt	2	
2	F1335	Washer	2	
3	S589	Bolt	2	
4	H1527	Metastatic bush	2	
5	H1529	Hemispherical washer	4	
6	H1581	Distance piece	2	
7	H1580	Rubber washer	2	
8	H2221	Cup	2	
9	14-1303	Nut	2	
10	H3875	Steering damper rod c/w knob	1	
11	D2438	Spring washer	1	
12	H435	Friction disc	1	
13	H1797	Anchor plate	1	
14	H95	Spring plate	1	
15	D2329	Washer	1	
16	H4102	Bottom nut	1	
17	—	Split pin ($\frac{3}{32} \times \frac{1}{2}$)		



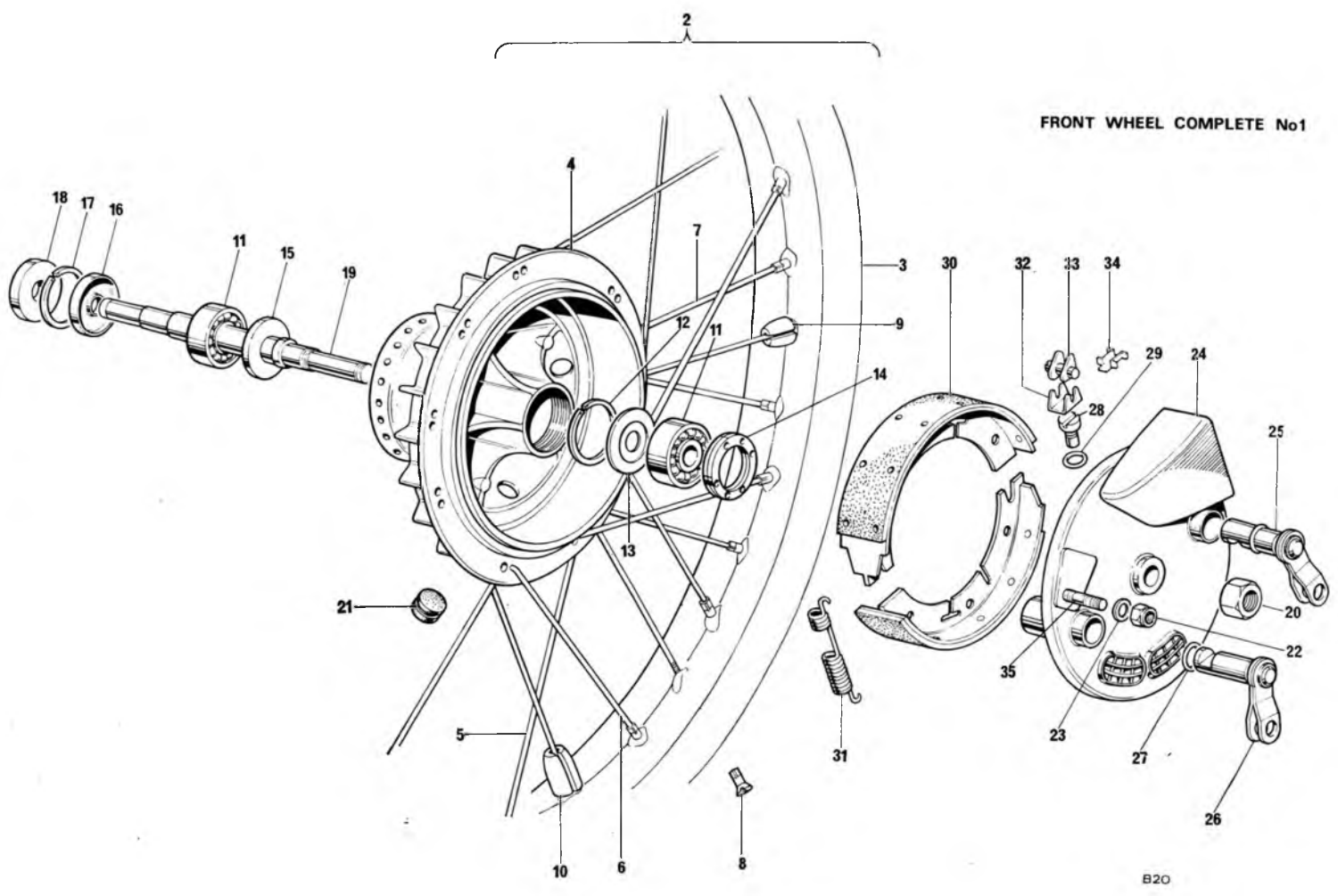

Fig. 21. FRONT WHEEL

FRONT WHEEL

1	W3845	FRONT WHEEL COMPLETE	1	
2	W3844	RIM, SPOKES AND HUB ASSEMBLY	1	
3	W3818	Wheel rim (WM2-19)	1	
4	W3658	Brake drum and hub	1	
5	W3820	Spoke (R.H.—inner)	10	
6	W3819	Spoke (R.H.—outer)	10	
7	W3821	Spoke (L.H.)	20	
8	W2294	Nipple	40	
9	W3969	Balance weight (short)	as required	
10	W3970	Balance weight (long)	as required	
11	W653	Bearing	2	
12	D2632	Circlip—R.H.	1	
13	W3797	Grease retainer—R.H.	1	
14	W3759	Lock ring—R.H.	1	
15	W1481	Grease cap inner—L.H.	1	
16	W1237	Grease cap outer—L.H.	1	
17	T280	Circlip—L.H.	1	
18	W3932	Distance piece	1	
19	W3796	Wheel spindle	1	
20	W2058	Nut wheel spindle	1	
21	D2594	Grommet brake drum	1	
22	14-1303	Nut	1	} Anchor plate to fork leg
23	D2340	Washer	1	
24	W3655	Brake anchor plate	1	
25	W3987	Brake lever front	1	
26	W3986	Brake lever rear	1	
27	D2639	“O” ring brake cam	2	
28	W3762	Tappet brake cam	2	
29	W3761	“O” ring brake tappet	2	
30	W3713	Brake shoe complete	2	
31	W3714	Return spring	2	
32	W3715	Cage brake shoe adjuster	2	
33	W3716	Micram adjuster	2	
34	W3717	Abutment pressing	2	
35	14-1635	Stud-anchor plate torque reaction	1	

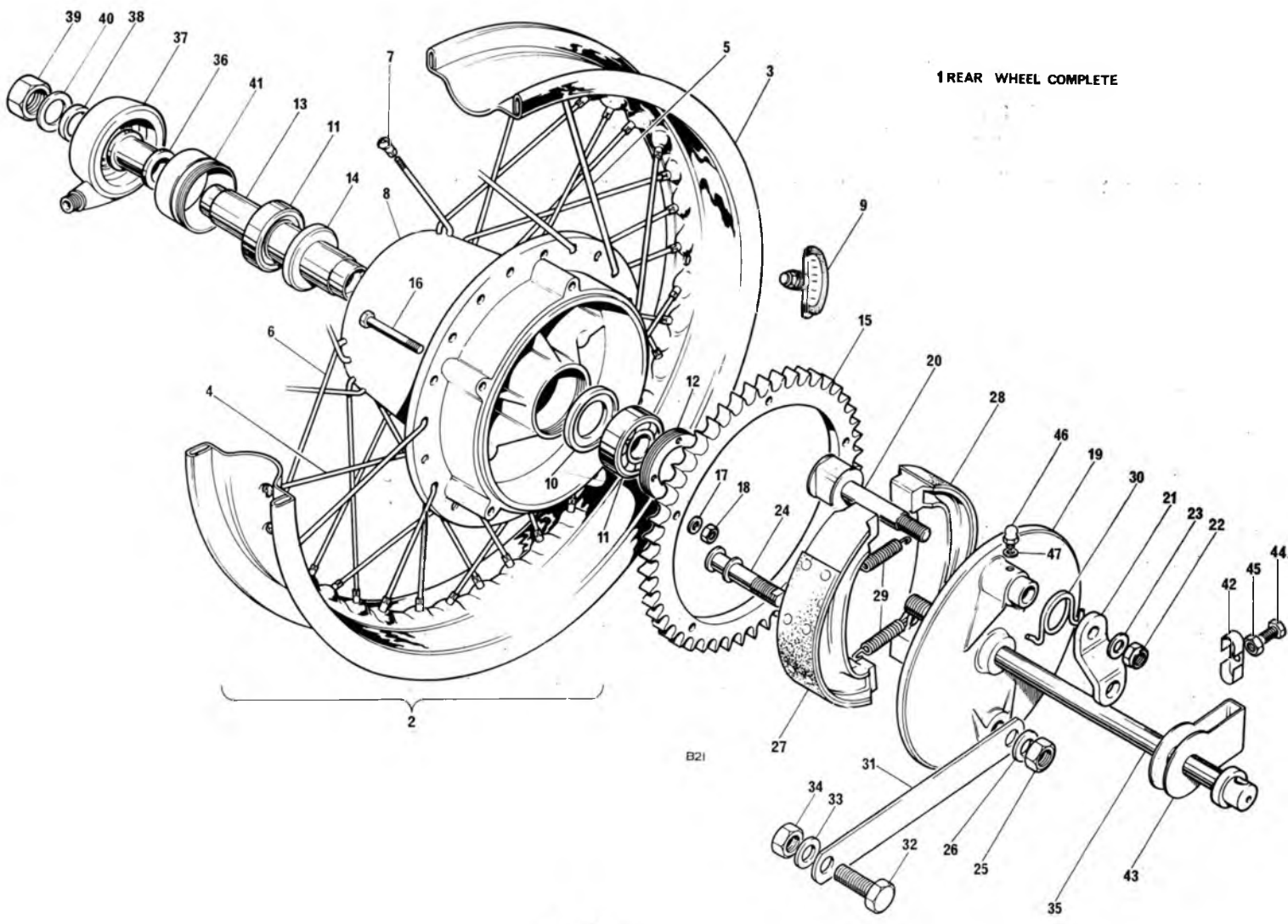

Fig. 22. REAR WHEEL

Ref. No.	Part No.	DESCRIPTION	QUANTITY	REMARKS
REAR WHEEL				
1	W3968	REAR WHEEL COMPLETE	1	
2	W3782	RIM SPOKES AND HUB ASSEMBLY	1	
3	W3784	RIM (Wm 3 x 18)	1	
4	W3724	Spoke (inner—L.H.)	10	
5	W3725	Spoke (outer—L.H.)	10	
6	W3726	Spoke—R.H.	20	
7	W2294	Nipple	40	
8	W3773	Hub and brake drum	1	
9	W3468	Tyre security bolt	2	
10	W3749	Support ring—L.H.	1	
11	W653	Bearing	2	
12	W3752	Locking ring—L.H.	1	
13	W3753	Spacer	1	
14	W1654	Grease retainer—R.H.	1	
15	W3747	Sprocket 47 teeth	1	
16	14-0207	Bolt	5	
17	D2320	Washer	5	
18	14-1301	Nut	5	
19	W3856	Brake anchor plate	1	
20	W3872	Brake cam	1	
21	W3877	Brake lever	1	
22	14-1303	Nut	1	
23	D2331	Washer	1	
24	W3870	Brake pivot	1	
25	14-0305	Nut	1	
26	D2431	Washer	1	
27	W3925	Brake shoe complete (leading)	1	
28	W3926	Brake shoe complete (trailing)	1	
29	W2328	Return spring (brake shoe)	2	
30	W3880	Return spring (brake lever)	1	
31	F12656	Brake torque arm	1	
32	14-0133	Bolt	1	
33	W2330	Washer	2	
34	14-1304	Nut	1	
35	W3965	Wheel spindle	1	
36	W3750	Distance piece inner	1	
37	D3213	Speedometer drive gearbox	1	
38	W3746	Distance piece outer	1	
39	14-1307	Nut	1	
40	F12266	Washer	1	
41	W3751	Speedometer drive ring	1	
42	F13082	Cover plate—swinging arm fork end	2	
43	W3742	Chain adjuster	2	
44	14-0107	Screw	2	
45	14-0301	Nut	2	
46	D1841	Grease nipple	1	
47	WE170	Fibre washer	1	

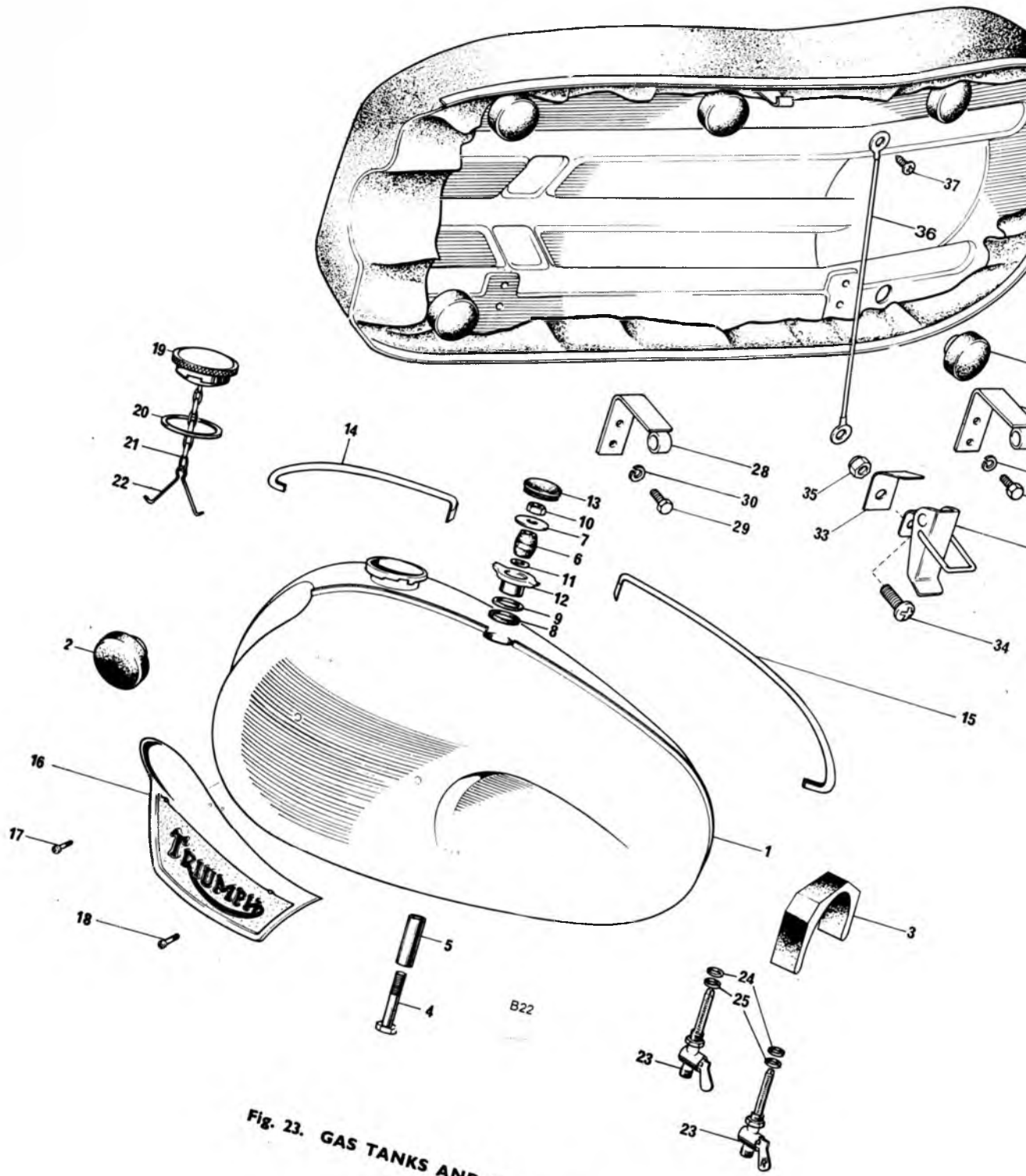
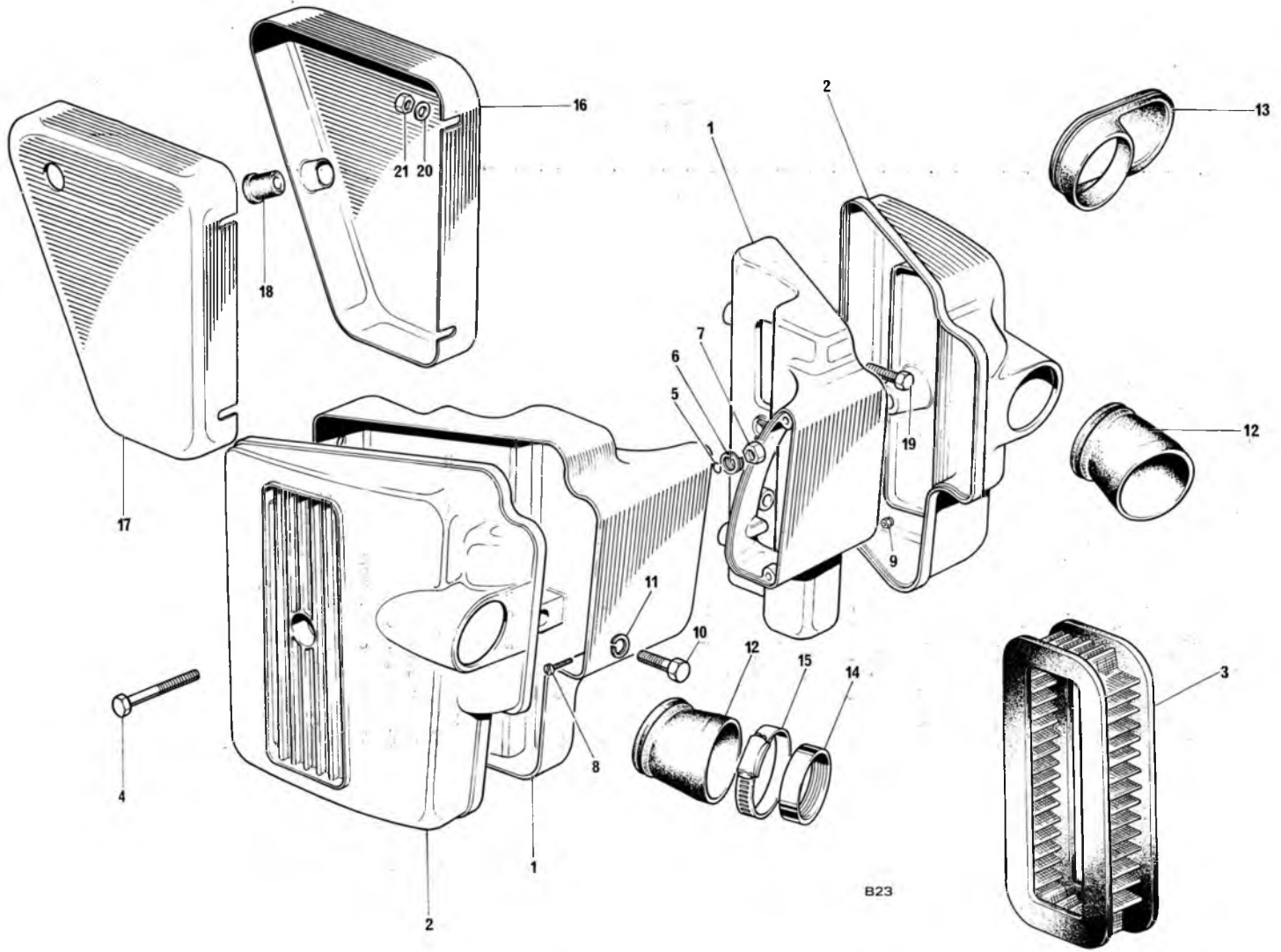

Fig. 23. GAS TANKS AND

GAS TANK AND TWINSEAT

1	F12996	Gas tank (3 gall.)	1	
2	F9062	Steady rubber	2	
3	F13021	Mounting rubber	2	
4	S1823	Centre fixing bolt	1	
5	F13133	Distance tube	1	
6	F10260	Mounting rubber	1	
7	F13320	Washer	1	
8	F13321	Rubber washer	1	
9	F13319	Mounting ring	1	
10	S1999	Nut	1	
11	D2330	Washer	1	
12	F13318	Beading holder	1	
13	F13068	Grommet	1	
14	F13134	Styling strip-front	1	
15	F13135	Styling strip-rear	1	
16	F9700	Tank motif—L.H.	1	
16	F9701	Tank motif—R.H.	1	
17	F11339	Screw—front—tank motif	2	
18	F7888	Screw—rear—tank motif	2	
19	F3220	Filler cap	1	
20	F4048	Joint washer	1	
21	F3217	Jack chain	1	
22	F3221	Clip	1	
23	F12800	Gas tap	1	
23	F12801	Gas tap—reserve	1	
24	E7351	Tap seal	2	
25	F10002	Washer	2	
26	F13634	Twinseat	1	
27	F13637	Twinseat cover	1	
28	F12867	Hinge	2	
29	14-0101	Bolt	4	
30	D2417	Spring washer	4	
31	F9093	Rubber buffer	5	
32	F13061	Catch assembly	1	
33	F12597	Spring—catch assembly	1	
34	14-0604	Screw	1	
35	14-1301	Nut	1	
36	D2087	Check wire	1	
37	D2381	Screw—self tapping	1	





B23

Fig. 24. AIR CLEANERS AND SIDE PANELS

Ref. No.	Part No.	DESCRIPTION	QUANTITY	REMARKS
AIR CLEANER AND SIDE PANELS				
	F13789	AIR CLEANER ASSEMBLY—L.H.	1	
	F13790	AIR CLEANER ASSEMBLY—R.H.	1	
1	F12749	Body—L.H.	1	
1	F12750	Body—R.H.	1	
2	F12751	Cover—L.H.	1	
2	F12752	Cover—R.H.	1	
	F13791	AIR CLEANER ASSEMBLY—L.H.	1	
	F13792	AIR CLEANER ASSEMBLY—R.H.	1	
1	F12798	Body—L.H.	1	
1	F12797	Body—R.H.	1	
2	F12839	Cover—L.H.	1	
2	F12840	Cover—R.H.	1	
3	D3072	Element	2	
4	14-0221	Bolt	2	
5	F12799	Circlip	2	
6	D2438	Washer	2	
7	14-0302	Nut	2	
8	D3539	Screw	2	
9	S501	Nut	2	
10	14-0217	Bolt	2	
11	D2418	Spring washer	2	
12	F12626	Connector pipe	2	
13	F12625	Connector pipe	1	
14	E11860	Carburetor adaptor	1 or 2	
15	D3536	Clip—Jubilee type	1 or 2	
16	F12502	Side panel—L.H.	1	
17	F12504	Side panel—R.H.	1	
18	F6673	Panel grommet	2	
19	14-0201	Bolt	4	
20	D2329	Washer	4	
21	14-1301	Nut	4	
Not illus.	D2103	Transfer	2	
Not illus.	D2104	Transfer	2	
Not illus.	D2102	Transfer	2	
LATER MODELS USE THE FOLLOWING:—				
5	F8245	Retainer	2	
10	14-0218	Bolt	2	
—	F9196	Spacer (use with 14-0218)	2	

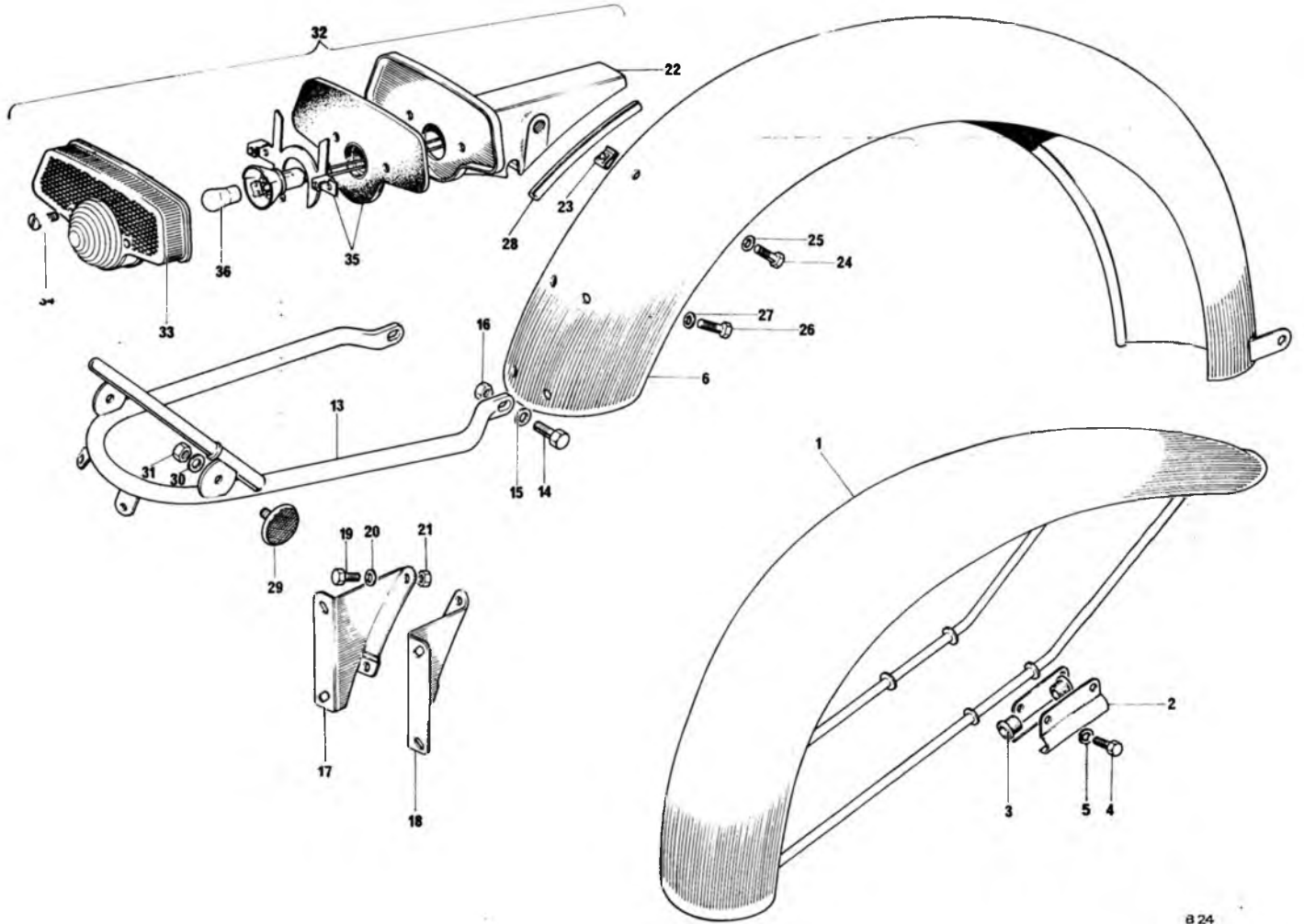

Fig. 25. FENDERS AND TAIL LAMP

Ref. No.	Part No.	DESCRIPTION	QUANTITY	REMARKS
----------	----------	-------------	----------	---------

FENDERS AND TAIL LAMP

1	H4260	Front fender	1	TR6R, T120R
1	H4065	Front fender	1	TR6C
2	H4022	Bracket	4	
3	H4021	Rubber bush	4	
4	14-0103	Bolt	4	
5	D2427	Spring washer	4	
6	F13566	Rear fender	1	TR6R, T120R
6	F13565	Rear fender	1	TR6C
7	14-0114	Bolt	2	
8	D2330	Washer	2	
9	14-1302	Nut	2	
10	14-0101	Bolt	3	
11	D2329	Washer	3	
12	14-1301	Nut	2	
13	F12768	Lifting handle	1	
14	14-0101	Bolt	2	
15	D2329	Washer	2	
16	14-1301	Nut	2	
17	F12727	Rear number plate bracket—L.H.	1	
18	F12728	Rear number plate bracket—R.H.	1	
19	14-0102	Bolt	4	
20	D2329	Washer	4	
21	14-1301	Nut		
22	F12786	Tail lamp support	1	
23	D3313	Captive nut	1	
24	14-6101	Bolt	1	
25	D2320	Washer	1	
26	14-0101	Bolt	2	
27	D2427	Washer	2	
28	F13213	Rubber beading strip	2	
29	57079	Reflector red (99-1162)	2	
30	D2391	Washer	2	
31	F4717	Nut	2	
32	53973	STOP AND TAIL LAMP 679 (99-0597)	1	
33	54577109	Lens (99-1046)	1	
34	144921	Screw (99-1189)	1	
35	54525286	Lamp base assembly		Reference only
36	380	Bulb (99-0542)	1	

LATER MODELS USE THE FOLLOWING:—

1	H4270	Front fender	1	TR6C
1	H4271	Front fender	1	TR6R, T120R

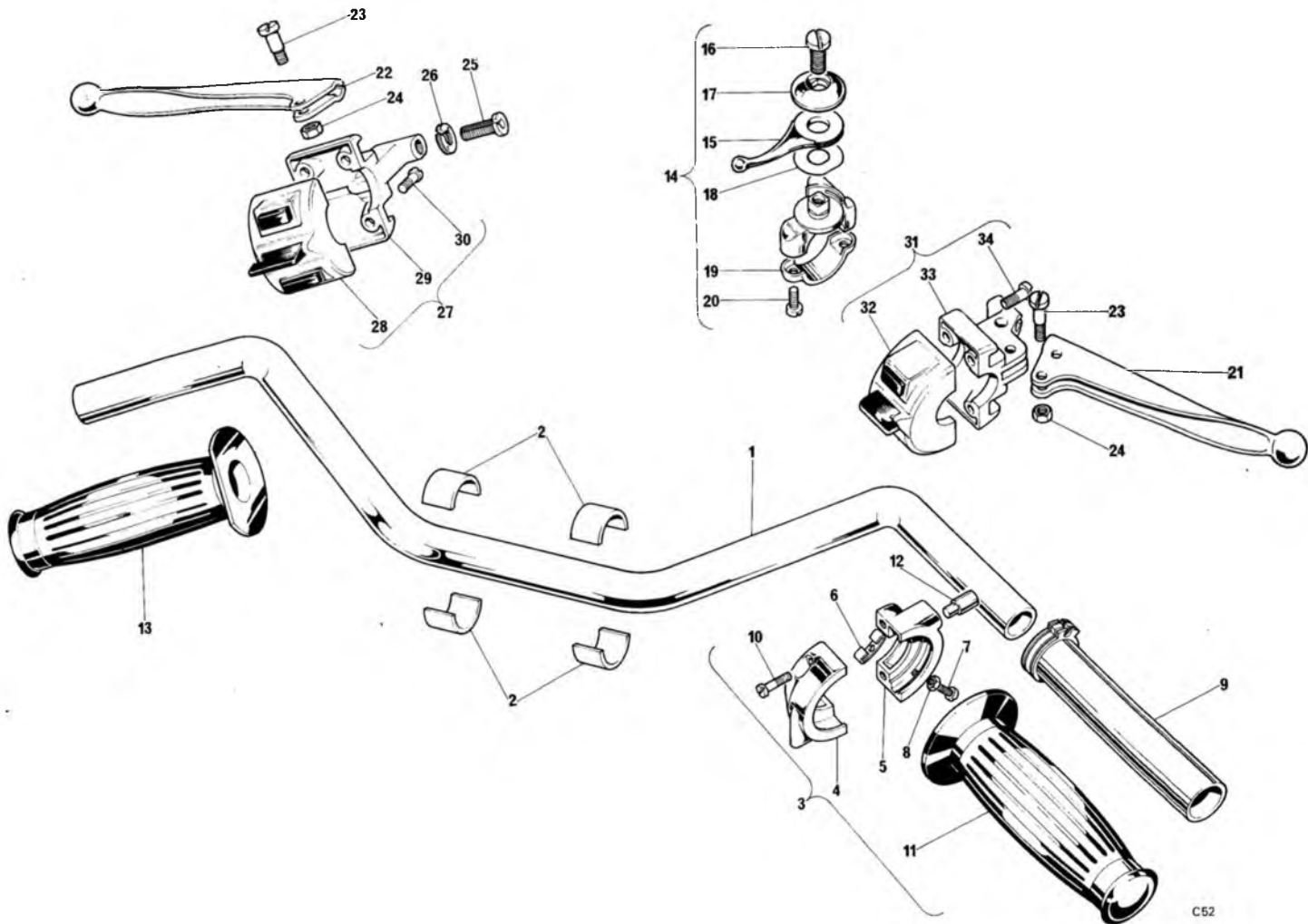

Fig. 26. HANDLEBAR AND CONTROL LEVERS

Ref. No.	Part No.	DESCRIPTION	QUANTITY	REMARKS
----------	----------	-------------	----------	---------

HANDLEBARS AND CONTROL LEVERS

1	H4252	Handlebar	1	
2	H1425	Sleeve, handlebar mounting	4	
3	16/364	TWISTGRIP (99-0248)	1	
4	16/328	Body, top half	1	
5	16/329	BODY, BOTTOM HALF	1	
6	16/008	Friction spring	Reference only	
7	16/009	Screw	Reference only	
8	16/010	Locknut	Reference only	
9	99-0244	Rotor	1	
10	11/013	Screw	2	
11	H958	Grip	1	
12	16/011	Cable stop	1	
13	H2124	Grip	1	
14	12/608	AIR CONTROL LEVER (D3246)	1	
15	12/556	Lever	Reference only	
16	12/607	Bolt	Reference only	
17	12/606	Cap	Reference only	
18	12/033	Spring washer	Reference only	
19	12/040	Clamp	Reference only	
20	11/014	Screw	Reference only	
21	D2628	Front brake lever (alloy)	1	
21	D3143	Front brake lever (steel)	1	(TR6R)
22	D2627	Clutch lever (alloy)	1	
22	D3144	Clutch lever (steel)	1	(TR6R)
23	S2048	Pivot pin	2	
24	14-1201	Nut	2	
25	D3585	Adjuster	2	
26	D3586	Lockring	2	
27	39595	HANDLEBAR SWITCH—L.H.	Reference only	
28	54033666	Switch half	Reference only	
29	54340883	Lever half (99-1215)	1	
30	54115246	Screw (99-1188)	4	
31	39596	HANDLEBAR SWITCH—R.H.	Reference only	
32	54033667	Switch half	Reference only	
33	54340882	Lever half (99-1187)	1	
34	54115246	Screw (99-1188)	4	
LATER MODELS USE THE FOLLOWING:—				
21	D3583	Front brake lever (alloy)	1	
21	D3648	Front brake lever (steel)	1	



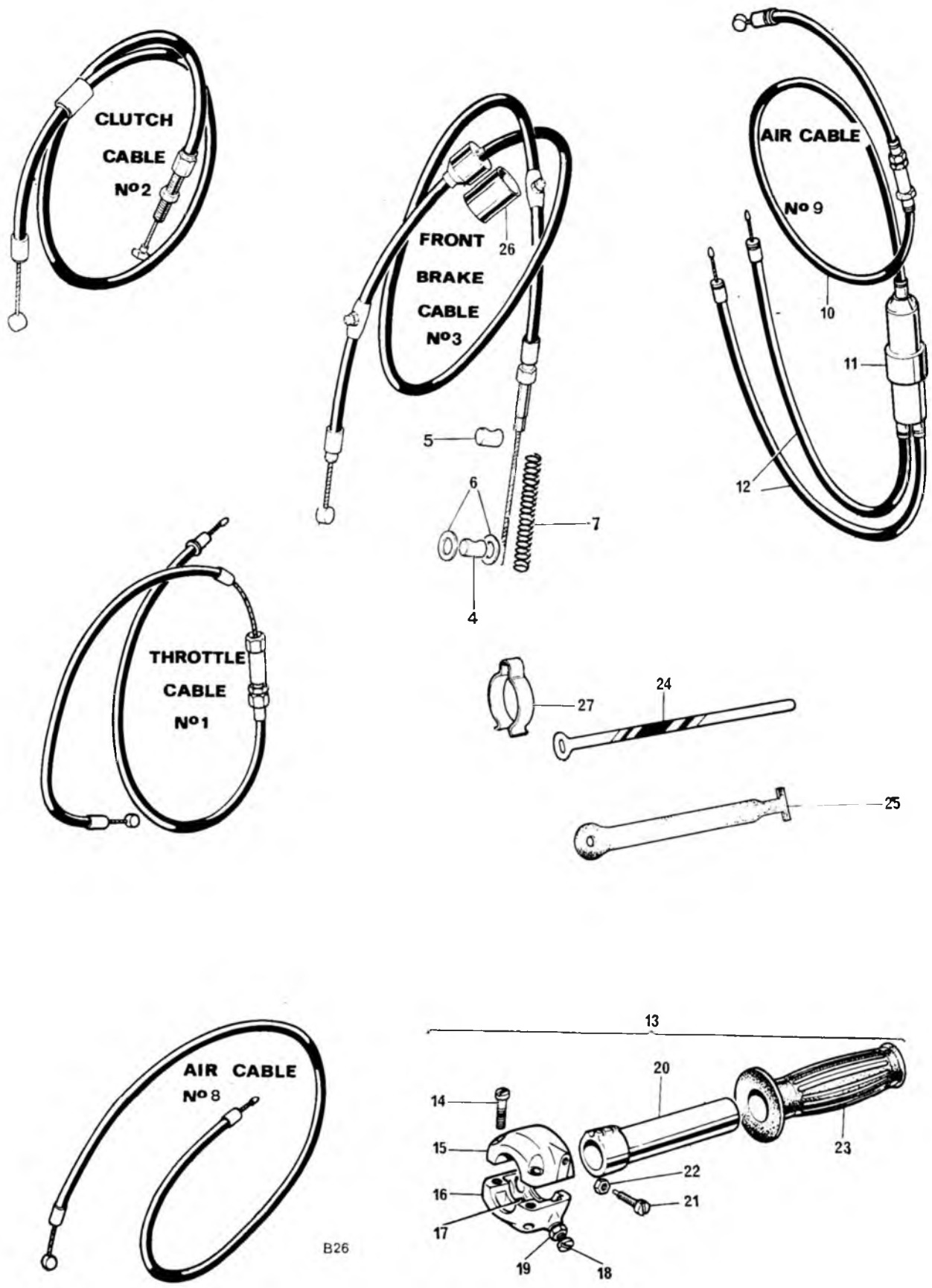

B26

Fig. 27. CONTROL CABLES

Ref. No.	Part No.	DESCRIPTION	QUANTITY	REMARKS
----------	----------	-------------	----------	---------

CONTROL CABLES

1	D1819	Throttle cable	2	T120R
1	D1806	Throttle cable	1	TR6C, TR6R
2	D3079	Clutch cable	1	
3	D3075	Front brake cable	1	
4	W3867	Bush—brake cable stop	1	
5	W3868	Bush—brake cable	1	
6	E12500	Washer	2	
7	W4014	Cable spring	1	
8	D1807	Air control cable	1	TR6C, TR6R
9	D3485	AIR CONTROL CABLE	1	T120R
10	D1818	Cable, lever to junction box	1	
11	244/104	Junction box (D685)	1	
12	D3486	Cable, junction box to carburetor	2	
13	313/13	TWIN ROTOR TWISTGRIP (99-0347)	1	T120R
14	18/084	Screw (99-0251)	2	
15	313/020	Body, top half (99-0348)	1	
16	313/021	BODY, BOTTOM HALF (99-0349)	1	
17	16/008	Friction spring		Reference only
18	210/007	Screw		Reference only
19	5/077	Nut		Reference only
20	313/004	Rotor (99-0344)	1	
21	210/008	Rotor stop screw (99-0338)	1	
22	5/077	Nut—rotor stop screw (99-0224)	1	
23	H2125	Grip	1	
24	D978	Cable clip	6	
25	D343/7	Cable clip	6	
26	D2086	Cover, front brake stop switch	1	
27	H4112	Handlebar clip	4	
LATER MODELS USE THE FOLLOWING:—				
3	D3557	Front brake cable	1	
4	W3996	Bush—brake cable stop	1	
5	W3997	Bush—brake cable	1	

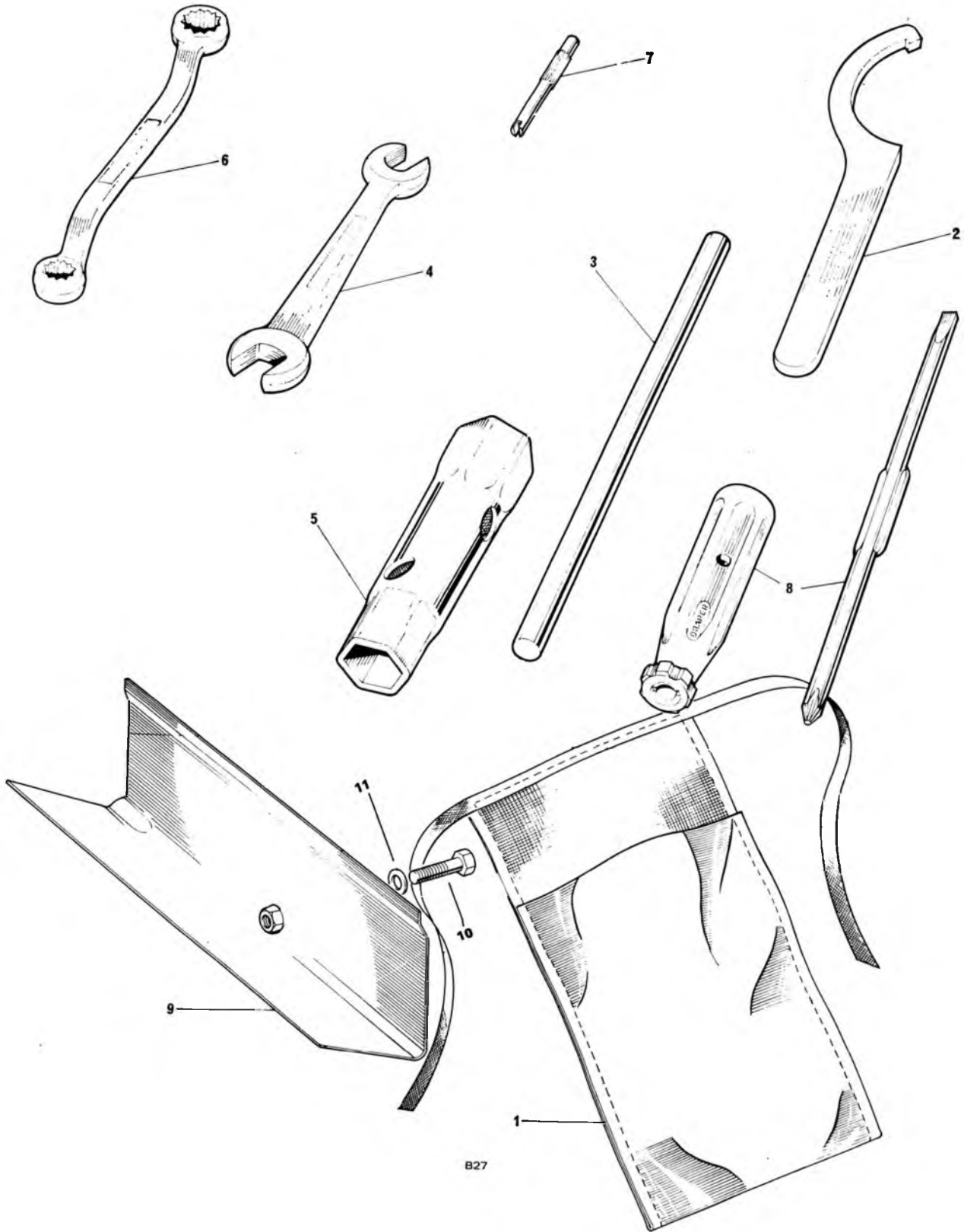

Fig. 28. TOOLKIT, PILLION FOOTRESTS AND LICENCE HOLDER

Ref. No.	Part No.	DESCRIPTION	QUANTITY	REMARKS
TOOLKIT				
	D2112	TOOLKIT COMPLETE	1	
1	D291	Tool roll	1	
2	D2184	Damper unit spanner	1	
3	D1911	Tommy bar	1	
4	D2084	Spanner—open ended	1	
5	D971	Box spanner	1	
6	D972	Ring spanner	1	
7	D974	Tyre valve key	1	
8	D767	Screwdriver	1	
9	F13292	Tool tray	1	
10	14-0101	Bolt	1	
11	D2329	Washer	1	

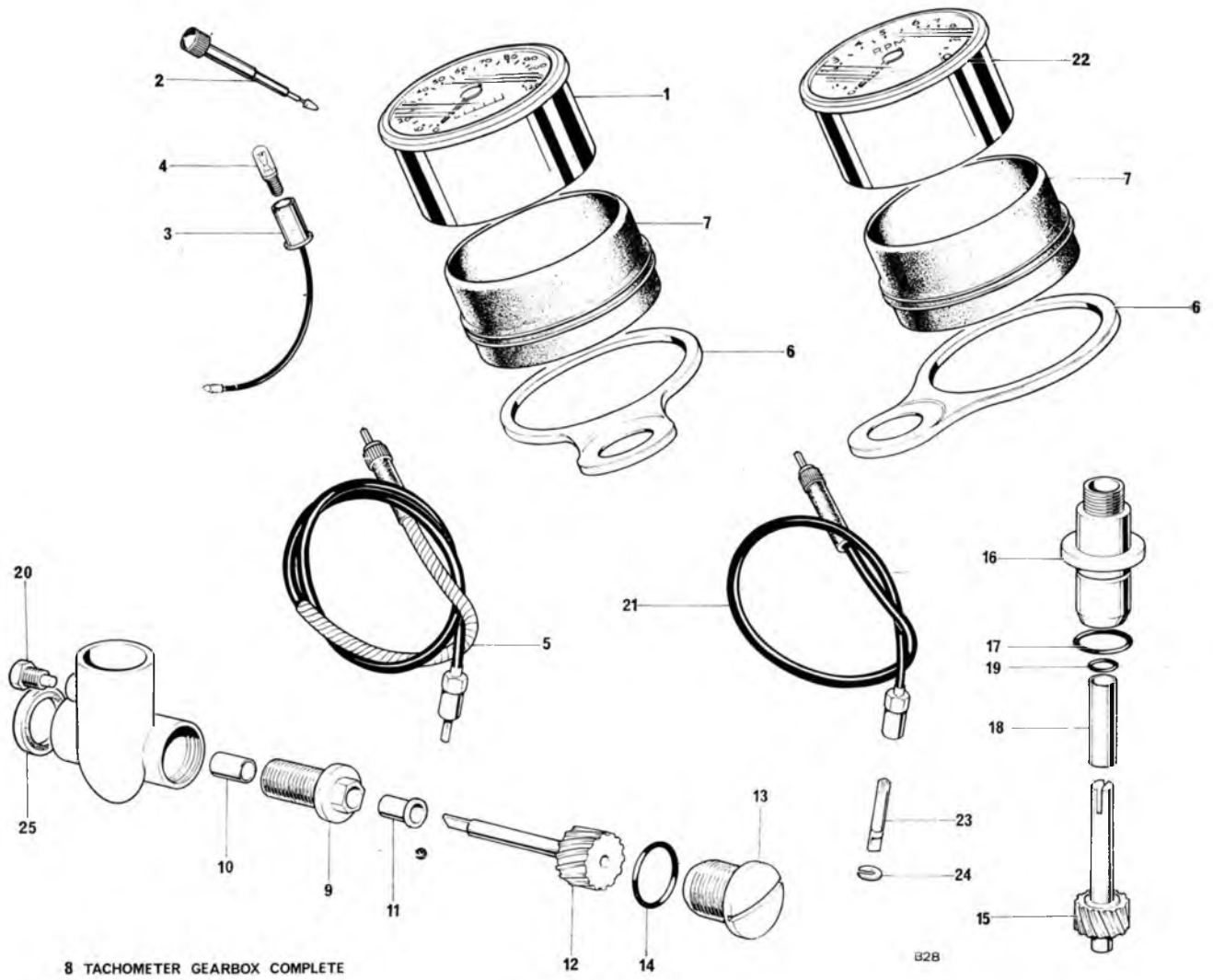

Fig. 29. SPEEDOMETER AND TACHOMETER

Ref. No.	Part No.	DESCRIPTION	QUANTITY	REMARKS
----------	----------	-------------	----------	---------

SPEEDOMETER AND TACHOMETER

1	SSM5007/00	Speedometer head (D2394)	1	
2	41-148-203-10	Trip control (99-0176)	1	
3	54959626	Bulb holder	Reference only	
4	643	Bulb (3W. MES)	Reference only	
5	D3249	Speedometer cable	1	
6	H4026	Mounting bracket	1	
			2	
7	D2600	Rubber cup	1	
			2	
Not illus.	D2391	Washer	4	
8	E9331	TACHOMETER GEARBOX (E5758 Body)—L.H. thread	1	
9	E9332	Securing screw—L.H. thread, U.N.	1	
10	Reference only	Bush	1	
11	Reference only	Flanged bush	1	
12	E5157	Driving gear	1	
13	E5759	End cap	1	
14	E6300	"O" ring	1	
15	E5578	Driven gear	1	
16	E6122	Driven gear housing	1	
17	E6299	"O" ring	1	
18	Reference only	Bush	1	
19	E3309	"O" ring	1	
20	E5881	Set screw	1	
21	D3282	Tachometer cable	1	
22	RSM3003/13	Tachometer (D2396)	1	
23	31-371-398	Spade	1	
24	D494	Circlip	1	
25	E7351	Sealing washer	1	
Not illus.	D546	Blanking plug (replaces tacho bulb holder)	1	



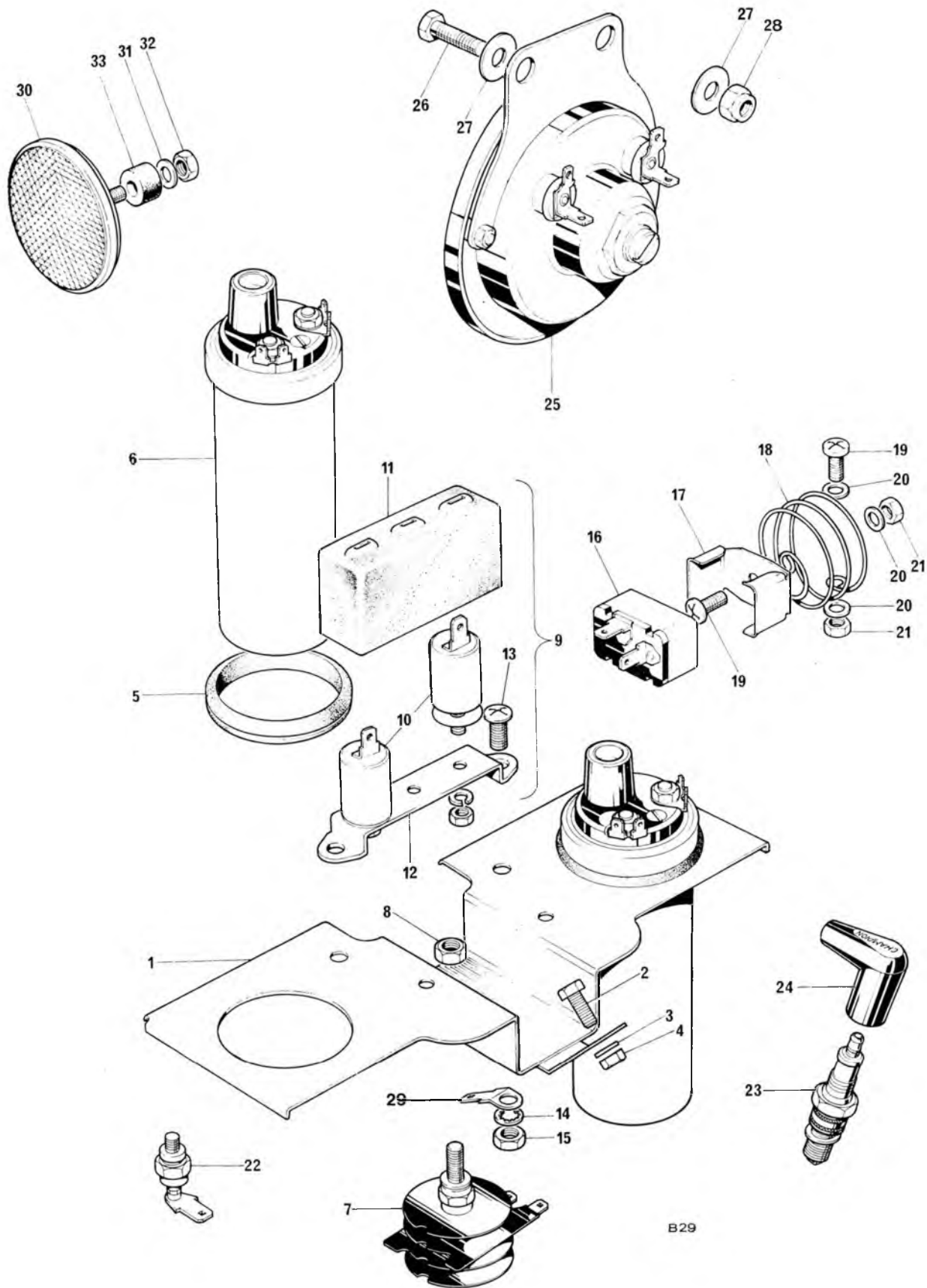

Fig. 30. COIL, CAPACITOR PACK, FLASHER UNIT, ZENER DIODE AND HORD

Ref. No.	Part No.	DESCRIPTION	QUANTITY	REMARKS
COIL, CAPACITOR PACK, FLASHER UNIT, ZENER DIODE AND HORN				
1	F12571	Mounting platform—electrical components	1	
2	14-0101	Bolt	1	
3	D2329	Washer	1	
4	14-1301	Nut	1	
5	F9561	Grommet—coil mounting	2	
6	45223	Ignition coil (17-M-12) (D2206)	2	
7	49072	Rectifier	1	
8	F5338	Nut	1	
9	47638	CAPACITOR PACK—2CP		Reference only
10	54420128	Capacitor	2	
11	54418528	Cover	1	
12	54418526	Base plate	1	
13	F10033	Bolt	2	
14	GS299	Shakeproof washer	2	
15	F3799	Nut	2	
16	35048	Flasher unit	1	
17	54385091	Clip, flasher unit	1	
18	D3614	Spring	1	
19	F10033	Bolt	2	
20	E2251	Washer	2	
21	F4717	Nut	2	
22	49345	Zener Diode (99-0590)	1	
23	N3	Sparking plug		Reference only
24	D262	Plug cover (Champion WC200)	1	
25	70216	Horn—6H	1	
26	14-0102	Bolt	2	
27	D2393	Washer	4	
28	14-1301	Nut	2	
29	54190038	Lucar black terminal		Reference only
30	57183	Reflector-amber	2	
31	D2391	Washer	2	
32	F4717	Nut	2	
33	F13522	Mounting rubber	2	

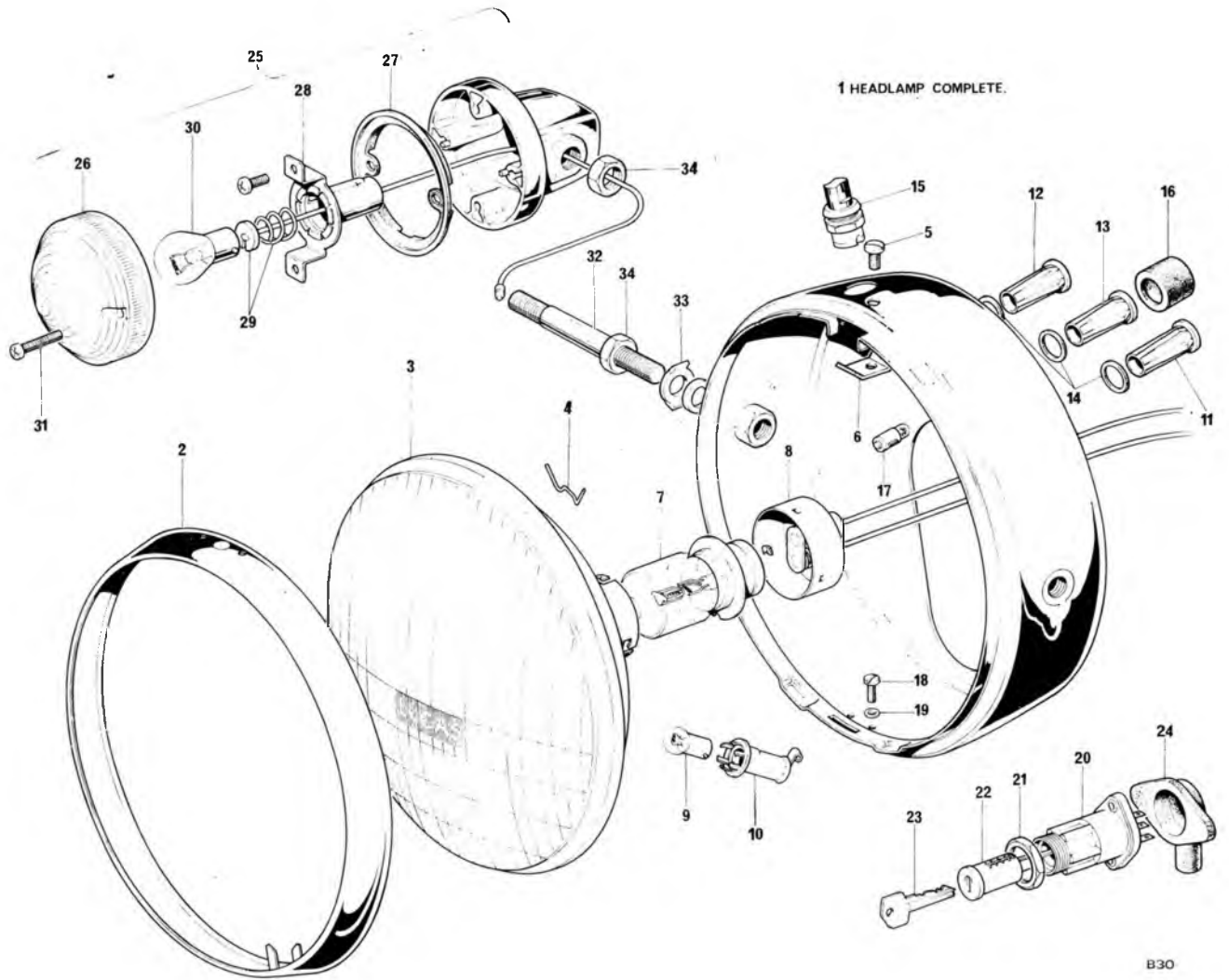

Fig. 31. HEADLAMP AND FLASHER LAMPS

B30

Ref. No.	Part No.	DESCRIPTION	QUANTITY	REMARKS
----------	----------	-------------	----------	---------

HEADLAMP AND FLASHER LAMPS

1	60260	HEADLAMP COMPLETE MCH 69	1	TR6R, T120R
2	553248	Rim (99-0692)	1	
3	54525272	Light unit	1	
4	504665	Fixing wire	6	
5	144921	Screw		Reference only
6	534296	Plate		Reference only
7	370	Main bulb (45/35W) (99-1214)	1	
8	554602	Bulbholder		Reference only
9	989	Pilot bulb (99-0548)	1	
10	54573590	Pilot bulbholder (99-1213)	1	
11	54363454	Warning light (Red) (99-1208)	1	
12	54363455	Warning light (Green) (99-1209)	1	
13	54363453	Warning light (Amber) (99-1207)	1	
14	54140331	Sealing washer (99-1210)	3	
15	31276	Light switch (99-1211)	1	
16	54525212	Shield, warning light		Reference only
17	281	Bulb, warning light (99-0537)	3	
18	54115106	Screw, headlamp fixing (99-1223)	2	
19	143086	Washer, headlamp fixing (99-1224)	2	
Not illus.	54959629	Wiring harness (99-1222)	1	
20	39565	IGNITION SWITCH (TYPE 149 SA) (99-1200)	1	
21	54130041	Nut		Reference only
22	F6981	IGNITION LOCK C/W KEY	1	
23	D622	Key (state serial number)		As required
24	H2262	Cover, ignition switch	1	
25	56147	FLASHER LAMP (99-1190)	4	
26	54581638	Lens	1	
27	54580300	Gasket		Reference only
28	554548	Bulbholder		Reference only
29	473832	Interior assembly		Reference only
30	382	Bulb (99-1192)	1	
31	54123401	Screw (99-1193)	2	
32	54582414	Stanchion, flasher lam	4	
33	143086	Washer	2	
34	1981721	Locknut	8	
		LATER MODELS USE THE FOLLOWING:—		
	H4247	Flasher mounting bracket	1	
	H4248	Front stanchion	2	
	F13525	Rear stanchion	2	
	14-0404	Nut (inside headlamp)	2	



08

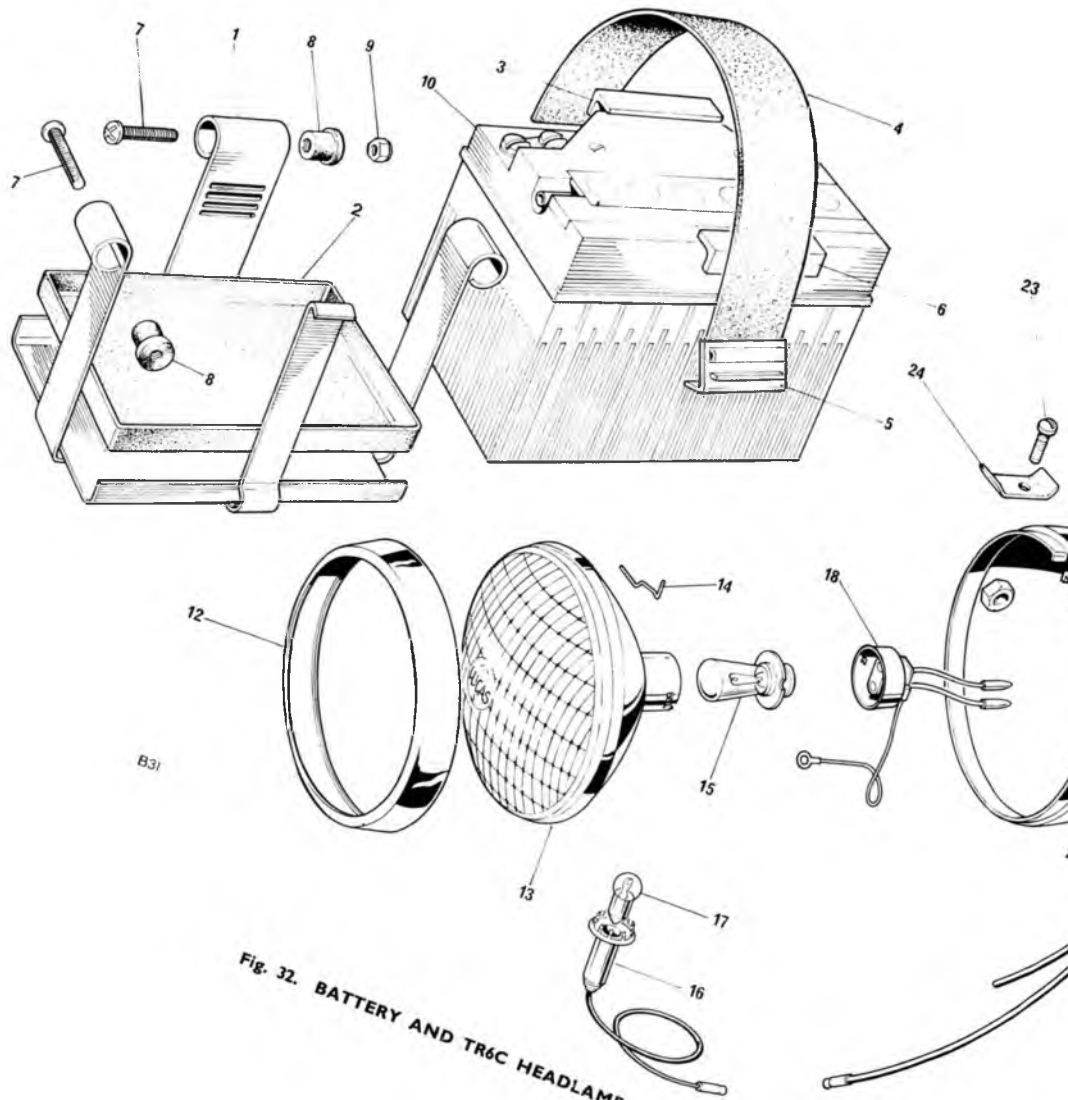

Fig. 32. BATTERY AND TR6C HEADLAMP

HEADLAMP ASSEMBLY No11

Ref. No.	Part No.	DESCRIPTION	QUANTITY	REMARKS
----------	----------	-------------	----------	---------

BATTERY AND TR6C HEADLAMP

1	F12512	Battery carrier	1	
2	F8091	Carrier tray	1	
3	F8255	Protective strip	2	
4	F9353	Retaining strap	1	
5	F13849	Buckle	1	
6	F13295	Protective strip	11	
7	F12508	Shoulder screw	3	
8	F6039	Rubber bush	3	
9	14-1301	Nut	1	
10	54027029	Battery—PUZ5A	1	
11	60262	HEADLAMP ASSEMBLY MCH 66	1	
12	534343	Rim	1	
13	54525272	Light unit	1	
14	504665	Fixing wire (99-0683)	6	
15	370	Bulb (45/35W vertical dip, pre-focus 99-1214)	1	
16	54573590	Bulbholder, pilot	1	
17	989	Bulb (3W.M.C.C. 99-0548)	1	
18	554602	Adaptor c/w leads	2	
Not illus.	54115106	Screw, lamp fixing	2	
Not illus.	143086	Washer (99-1224)	2	
19	31272	Lighting switch	1	
20	153631	Nut for lighting switch	Reference only	
21	144921	Screw	Reference only	
22	534296	Plate (99-0690)	1	
23	54363454	Warning light, red	1	
24	281	Bulb (2W.BA75) (99-0537)	2	
25	54363455	Warning light, green (99-1209)	1	
26	54140331	Sealing washer (99-1210)	3	
27	54363453	Warning light amber (99-1207)	1	
28	54525212	Warning light shield	Reference only	

STANDARD HARDWARE SPECIFICATION BOLTS

Part No.	Material	Thd. dia.	Length under head	Min. length of thread	Hexagon A.F.
S1822	Steel	$\frac{5}{16}$ " UNF	$\frac{1}{2}$ "	$\frac{27}{64}$ "	0.500"
S1910	"	$\frac{3}{8}$ " UNF	$\frac{13}{16}$ "	$\frac{13}{16}$ "	0.565"
S1919	"	$\frac{5}{16}$ " UNC	$1\frac{5}{8}$ "	$\frac{7}{8}$ "	0.500"
S2010	"	$\frac{1}{4}$ " UNF	$\frac{13}{16}$ "	$\frac{3}{8}$ "	0.375"
14-0101	"	$\frac{1}{4}$ " UNF	$\frac{1}{2}$ "		0.438"
14-0102	"	$\frac{1}{4}$ " UNF	$\frac{5}{8}$ "		0.438"
14-0103	"	$\frac{1}{4}$ " UNF	$\frac{3}{4}$ "		0.438"
14-0113	"	$\frac{5}{16}$ " UNF	$\frac{5}{8}$ "		0.500"
14-0114	"	$\frac{5}{16}$ " UNF	$\frac{3}{4}$ "		0.500"
14-0115	"	$\frac{5}{16}$ " UNF	$\frac{7}{8}$ "		0.500"
14-0128	"	$\frac{3}{8}$ " UNF	1"		0.563"
14-0208	"	$\frac{1}{4}$ " UNF	$2\frac{1}{4}$ "	$\frac{3}{4}$ "	0.438"
14-0216	"	$\frac{5}{16}$ " UNF	$1\frac{1}{8}$ "	$\frac{7}{8}$ "	0.500"
14-0217	"	$\frac{5}{16}$ " UNF	$1\frac{1}{4}$ "	$\frac{7}{8}$ "	0.500"
14-0219	"	$\frac{5}{16}$ " UNF	$1\frac{1}{2}$ "	$\frac{7}{8}$ "	0.500"
14-0220	"	$\frac{5}{16}$ " UNF	$1\frac{3}{4}$ "	$\frac{7}{8}$ "	0.500"
14-0225	"	$\frac{5}{16}$ " UNF	3"	$\frac{7}{8}$ "	0.500"
14-0228	"	$\frac{5}{16}$ " UNF	4"	$\frac{7}{8}$ "	0.500"
14-0234	"	$\frac{3}{8}$ " UNF	$1\frac{3}{4}$ "	1"	0.563"
14-0236	"	$\frac{3}{8}$ " UNF	$2\frac{1}{4}$ "	1"	0.563"
14-0239	"	$\frac{3}{8}$ " UNF	3"	1"	0.563"
14-0240	"	$\frac{3}{8}$ " UNF	$3\frac{1}{4}$ "	1"	0.563"
14-0242	"	$\frac{3}{8}$ " UNF	4"	1"	0.563"
14-0251	"	$\frac{7}{16}$ " UNF	$2\frac{3}{4}$ "	$1\frac{1}{4}$ "	0.625"
14-6102	"	$\frac{1}{4}$ " UNC	$\frac{5}{8}$ "		0.438"
14-6115	"	$\frac{5}{16}$ " UNC	$\frac{7}{8}$ "		0.500"

NUTS

Part No.	Material	Thd. dia.	Hexagon A.F.	Thickness	Remarks
S778	Steel	No. 10 UNF	0.375"	0.225"	Cleveloc
S1852	"	$\frac{5}{16}$ " UNF	0.437"	0.330"	Philidas
S1906	"	$\frac{1}{4}$ " UNF	0.438"	0.188"	Plain
S1908	"	$\frac{5}{16}$ " UNF	0.438"	0.313"	Plain
S1914	"	$\frac{3}{4}$ " UNEF	1.125"	0.250"	Plain
S2012	"	$\frac{7}{8}$ " UNEF	1.313"	0.438"	Plain
S2013	"	$\frac{3}{4}$ " UNEF	1.313"	0.313"	Plain
S2014	"	$\frac{3}{4}$ " UNEF	1.313"	0.438"	Plain
14-0301	"	$\frac{1}{4}$ " UNF	0.438"	0.224"	Plain
14-0302	"	$\frac{5}{16}$ " UNF	0.500"	0.271"	Plain
14-0401	"	$\frac{1}{4}$ " UNF	0.438"	0.161"	Lock
14-0402	"	$\frac{5}{16}$ " UNF	0.500"	0.192"	Lock
14-0403	"	$\frac{3}{8}$ " UNF	0.563"	0.224"	Lock
14-0701	"	$\frac{1}{4}$ " UNF	0.438"	0.203"	Philidas
14-0702	"	$\frac{5}{16}$ " UNF	0.500"	0.246"	Philidas
14-0703	"	$\frac{3}{8}$ " UNF	0.563"	0.296"	Philidas
14-1201	"	$\frac{1}{4}$ " UNF	0.438"	0.285"	Stiffnut
14-1202	"	$\frac{5}{16}$ " UNF	0.500"	0.335"	Stiffnut
14-1301	"	$\frac{1}{4}$ " UNF	0.438"	0.245"	Stiffnut
14-1302	"	$\frac{5}{16}$ " UNF	0.500"	0.290"	Stiffnut
14-1303	"	$\frac{3}{8}$ " UNF	0.563"	0.320"	Stiffnut
14-1304	"	$\frac{7}{16}$ " UNF	0.688"	0.375"	Stiffnut
14-1305	"	$\frac{1}{2}$ " UNF	0.750"	0.435"	Stiffnut
14-1902	"	$\frac{5}{16}$ " UNF	0.500"	0.361"	Nyloc
14-1903	"	$\frac{3}{8}$ " UNF	0.563"	0.375"	Nyloc

SCREWS

Part No.	Type of head	Material	Thd. dia.	Length under head	Type of drive
S1916	Cheese head	Steel	$\frac{1}{4}$ " UNC	$1\frac{1}{8}$ "	Cross recess
S1917	Cheese head	"	$\frac{1}{4}$ " UNC	$2\frac{5}{8}$ "	Cross recess
S1918	Cheese head	"	$\frac{1}{4}$ " UNC	$2\frac{3}{8}$ "	Cross recess
S1920	Hex. head	"	$\frac{1}{4}$ " UNC	$\frac{23}{64}$ "	Slot
S1929	Countersunk (82°)	"	$\frac{1}{4}$ " UNC	$\frac{17}{32}$ "	Slot
S2079	Cheese head	"	No. 10 UNF	$\frac{1}{2}$ "	Pozidrive
14-0604	Cheese head	"	$\frac{1}{4}$ " UNF	$\frac{1}{2}$ "	Cross recess
14-6505	Countersunk (82°)	"	$\frac{1}{4}$ " UNC	$\frac{7}{8}$ "	Cross recess
14-6607	Cheese head	"	$\frac{1}{4}$ " UNC	$\frac{7}{8}$ "	Cross recess
14-6608	Cheese head	"	$\frac{1}{4}$ " UNC	1"	Cross recess
14-6609	Cheese head	"	$\frac{1}{4}$ " UNC	$1\frac{1}{4}$ "	Cross recess
14-7019	Socket head	"	$\frac{5}{16}$ " UNC	$\frac{7}{8}$ "	Hex. socket
14-7024	Socket head	"	$\frac{5}{16}$ " UNC	2"	Hex. socket

WASHERS—PLAIN

Part No.	Material	i/dia.	o/dia.	Thickness
S25-1	Steel	0.273"	0.563"	0.048"
S25-2	Steel	0.398"	0.750"	0.063"
S25-3	Steel	0.336"	0.625"	0.063"
S25-6	Steel	0.531"	1.031"	0.092"
S25-13	Steel	0.266"	0.469"	0.064"

WASHERS—SPRING

Part No.	Material	i/dia.	o/dia.	o/a height	Thickness
S26-1	Spring Steel	$\frac{3}{8}$ " clearance	$\frac{19}{32}$ "	$\frac{7}{32}$ "	0.104"
S26-2	" "	$\frac{1}{4}$ " clearance	$\frac{13}{32}$ "	$\frac{3}{16}$ "	0.064"
S26-16	" "	$\frac{17}{32}$ "	$\frac{7}{8}$ "	$\frac{7}{32}$ "	0.040**
S648	" "	$\frac{5}{16}$ " clearance	$\frac{1}{2}$ "	$\frac{5}{32}$ "	0.080"

** Double coil.

PARTS REQUIRED FOR 5 SPEED GEARBOX—OPTIONAL

1	E12791	Crankcase—timing side	1	
2	D3500	Oil seal	1	
3	E3789	Cover plate	1	
4	D3493	High gear bearing	1	
5	D3512	Oil seal	1	
6	T4360 57-4789	Gearbox camplate	1	
7	T4364	Selector fork—M/S 4th gear	1	
8	T4366	Selector fork—L/S 3rd gear	1	
9	T4368*	Selector fork—L/S 1st gear	1	
10	T4372 57-4781	M/S High gear	1	
11	D3511	Needle roller bearing	2	
12	D3500	Oil seal	1	
13	T4432	Main shaft	1	
14	T4376	M/S 4th gear	1	
15	T4377	M/S 3rd gear	1	
16	T4380*	M/S 1st and 2nd gear	1	
17	T4371 57-4900	Layshaft	1	
18	T4384 57-4900	L/S 4th gear	1	
19	D3494	Circlip	1	
20	T4383 57-4900	L/S high gear	1	
21	T4387*	L/S 3rd gear	1	
22	T4388*	L/S 2nd gear	1	
23	T4391*	L/S 1st gear	1	
24	D3494 57-4790	Circlip	1	
25	T4381*	Driving dog	1	
26	T4407	Gearbox inner cover	1	
27	T4402	Leaf spring	1	
28	T4363	Quadrant	1	
29	T4374 408	Plunger quadrant	1	
30	T4403	Plunger	2	
31	T4397	Gearbox sprocket—19T	1	
32	T4398	Gearbox sprocket—18T	1	
33	T4396	Locknut	1	
34	T4395 57-4909	Locking washer	1	

* USE UPDATE 99-3802 (MUST BE USED AS KIT)

